

刺绣机电脑

Computerized Embroidery Machine Controller

BECS-A15Pro-FW

Version: 2023-01

操作手册

OWNER'S MANUAL

<http://www.dahaobj.com/en/sh.asp>



Contents

Chapter 1 General Information	1
1.1 Warnings and Cautions	1
1.2 Main Features	3
1.3 Technical Specifications	6
Chapter 2 Embroidery Guide	7
2.1 Structure and Usage Instruction of Control Panel	7
2.2 Instruction of the Main Interface	8
2.3 Basic Procedure of Embroidery	16
2.4 Normal Embroidery, Returning and Patching	20
2.5 Embroidery Operation	20
2.6 Thread-Breakage Detection	20
2.7 Working Status	21
Chapter 3 U Disk Management	23
3.1 Select U Disk	23
3.2 Pattern Preview	25
3.3 Pattern Input	26
3.4 Directory Operation	27
3.5 Create a New Directory in the Current Directory	27
3.6 Delete Objects from U Disk (including pattern file and directory)	28
3.7 Formatting U Disk	29



Chapter 4 Common Parameters and Color-Changing Order	30
4.1 Settings of Common Parameters	30
4.1.1. Settings of X-Y Scale	31
4.1.2. Settings of Rotate Angle	32
4.1.3. Pattern Direction	32
4.1.4. Prior Mode	33
4.1.5. Rep. Mode	33
4.1.6. Rep. Order	33
4.1.7. X-Y Rep. Times	33
4.1.8. X-Y Rep. Interval	33
4.2 Settings of Color-changing Order	34
4.2.1. Color-changing Interface	34
4.2.2. Settings of Color-Changing Order	35
4.2.3. Set Needle Bar Color	36
Chapter 5 Settings of Embroidery Parameters	38
5.1 Procedure for Setting General Parameters	39
5.2 Instruction on Some Functions within General Parameters	40
5.2.1. Cyclic Embroidery Function	40
5.2.2. Brake Adjustment (A Must for New Machine)	41
Chapter 6 Memory Pattern Management	42
6.1 Memory Pattern Management Interface and Other Memory Pattern Operation Interfaces	42
6.2 Select Pattern for Embroidery	44
6.3 Memory Pattern Preview	44



6.4 Pattern Output 46

6.5 Copy the Memory Pattern 48

6.6 Create Outline Pattern 49

6.7 Create High-speed Pattern 49

6.8 Divide Pattern 50

6.9 Create Parameter Pattern 51

6.10 Mosaic Pattern 52

6.11 Create Combined Pattern 53

6.12 Satin Stitch Adjustment 55

Chapter 7 Letter Pattern Operation 56

7.1 Enter Main Interface for Letter Embroidery 56

7.2 Input Letter String for Embroidery 56

7.3 Adjust Letter Pattern 57

7.4 Save Letter Pattern 61

Chapter 8 Assistant Operation 63

8.1 Frame Selection 63

8.2 Set Frame Origin 64

8.3 Set Offset Point 65

8.4 Frame Origin Recovery 66

8.5 Positioning Idling 67

8.5.1. Low Speed Idling Forward 68

8.5.2. Low Speed Idling Backward 68

8.5.3. High Speed Idling Forward 68

8.5.4. Go to Next Color 69



8.5.5. Forward Idling	69
8.5.6. Backward Idling	69
Chapter 9 Assistant Operation Function	70
9.1 Needle Down	70
9.2 Wifi NetWord Configuration	71
Chapter 10 Other Functions	75
10.1 Statistics	75
10.2 Machine Debugging	77
10.2.1. Touch Screen Correction	78
10.2.2. Function Configuration	80
10.3 Language	81
10.4 Date Set	82
10.5 Information	82
Chapter 11 About JF Sequin Embroidery	84
11.1 Brief of Sequin Embroidery	84
11.2 Embroidery Procedure of Sequin	85
11.3 Input Sequin Design	85
11.4 Edit Sequin Design	86
11.5 Setting of Multi-Sequin Embroidery Parameters	91
11.6 Manual Operation of Sequin Embroidery	92
11.7 Debugging Multi-Sequin Embroidery	93
11.8 Sequin Mending	94
Chapter 12 Operation of Zigzag Embroidery	95



12.1 Functions	95
12.2 Key Technical Indexes	95
12.3 Procedure of Zigzag Embroidery	95
12.4 Related Parameter and Setting Mode	95
12.5 Relative Operations of Zigzag Embroidery	97
12.5.1. Shift between Flat Embroidery Position and Zigzag Embroidery Position	97
12.5.2. M Axis Operation of Zigzag Embroidery	99
Chapter 13 Taping Embroidery	100
13.1 Function Introductions	100
13.2 Main Technical Specification	100
13.3 Parameters and setting	100
13.4 Relative Operations of Special Embroidery	102
13.4.1. Shift between Flat Stitch Head and Special Head	102
13.4.2. M Axis Operation of Special Embroidery	103
13.4.3. Operations of Clamp Foot	104
13.5 Debugging Special Embroidery	104
13.6 Steps on Special Embroidery	105
13.7 Mechanical Category and Driving Mode Selection for Special Embroidery Machines	105
Chapter 14 Online Update of Main Software	107
Chapter 15 Update of Software in Peripheral Board	110
Appendix 1 Parameter List	113
Appendix 2 Directions of U Disk Operation	126



Appendix 3 Automatic Position Limitation Function Instructions for
Apparel Embroidery 127

Appendix 4 A15Pro-FW Controller Operation Quick Guide 133

There will be no further notice in case of any change of specifications.



Chapter 1 General Information

Thank you for using Dahao Computerized Control System for Embroidery Machine.

Please read this manual carefully so as to operate the machine correctly and effectively.













Besides that, you should keep this manual properly for future use.

1.1 Warnings and Cautions

In order to avoid fire, electrical shock or unpredicted injuries, you should follow the listed safety rules.

Matters for Attention on Usage	
⚠ Danger	During the operation, do not try to open the machine box. The high voltage contained in some parts is deadly. The rotating parts may cause serious injury.
⊘ Forbidden	Don't expose the machine to humidity gas, poisonous gas, water, and dust.
⊘ Forbidden	Don't store or operate the machine in the vibration area, which may cause trouble to the machine.
⚠ Attention	Please abide all the warnings and safety requirements to ensure the security.
⚠ Attention	LCD screen is fragile. Do not use the hard or sharp item to click the screen.
⚠ Attention	Please insert U disk correctly and don't force it in, otherwise, USB interface or U disk may get damaged
⚠ Attention	We will add appendix if necessary. If there is any difference between the manual and appendix, the content in the appendix shall take precedence.
Matters for Attention on Transportation and Loading	
⚠ Attention	When moving the machine, please not to hold the cable.
⚠ Attention	Please abide all the warnings and safety requirements to ensure the security.
⚠ Compulsory Requirements	Overloading may cause serious loss. Please load according to the instruction on the box



Matters for Attention on Installation	
 Attention	Don't jam the vent on the device. Don't insert other items into the machine, or it may get fire.
 Attention	Make sure the installation direction is correct.
 Attention	Don't expose the machine to humidity gas, corrosive gas, water, and other flammable material.
Matters for Attention on Cable Connection	
 Forbidden	Don't test the insulation of the circuit loop.
 Forbidden	Never try to connect the overloaded electronic device on the connectors (like sockets or terminals).
 Attention	The insulation condition of each cable (no matter signal cable or power cable) should be ensured.
 Attention	The signal cables and power cables should be separated. Never tie them together.
 Attention	All the cables should be well fixed. Don't put any strength on cables. Make sure each turning point of cable is well protected. Add shelter pipes to increase insulating capability if necessary.
 Attention	must be grounded. The equipment-grounding conductor should use the wire with insulation having an outer surface that is green, with or without yellow stripes. the cross-sectional area of the wire shall not be less than 2mm ² , and the grounding resistance should be less than 10Ω. The equipment-grounding conductor must be pressed crimping to the circular pre-insulated terminal and connected to the position where the grounding mark of the machine case is.
Matters for Attention on Operation	
 Danger	Don't operate the machine when there is any damage on the shelter of the running parts.
 Forbidden	When machine is running, do not touch any running part.
 Attention	Make sure the configuration of power supply is in normal. Use stabilized voltage power supply when the change of voltage is beyond the range of -10%~10%.
 Attention	In case of warning, please check out the problem. Operation can only be carried out again when problem is solved.



⚠ Attention	The power supply switch has over-current protection function. If the over-current switch is activated, the switch can only be closed after 3 minutes.
Matters for Attention on Maintenance and Inspection	
⚠ Warning	If you need to open the machine cover, please cut off the power supply at first. Due to the capacitance, operator must wait at least one minute before opening the machine cover.
⚠ Attention	Circuit boards can be damaged by static. The circuit boards can only be disassembled by professional technicians.
⚠ Attention	If machine is inactive for a while temporarily, users must power on the machine regularly (once by every 2 or 3 days, more than an hour for each time).
⚠ Attention	If machine is inactive for a long time, users should have the machine checked before power-on.
Matters for Attention on Rejection	
⚠ Attention	Rejection should obey the rules and regulations set by national industrial electronic standards.

1.2 Main Features

1. User-friendly Interface on Touching Panel

The adoption of the touching panel technology offers user the delightful operation and easy learning. The beautiful screen display turns everyday work into joyful experiences.

2. Huge Memory Capacity

The memory capacity reaches 100 million stitches, which can meet demands of different customers.

3. Maximum Stitch Amount of One Pattern Reaches Two Million

At present a single pattern in the system has the maximum of 2 million stitches and 1,000 times of automatic color changing.

4. Multi-Task Parallel Operation and Free Shift among Tasks

During the embroidery, actions like pattern input & output, preparation for the following patterns and modification of parameters can be carried out.



5. Storage of Frequently Used Parameters and Color-Changing Order for Each Pattern

Pattern will be saved along with its parameters, color-changing orders and needle bar colors. System can save the operational details for each pattern. Users can set parameters for a pattern during the embroidery process of the previous pattern, which will save time and improve efficiency. Moreover, it is one basis to realize network management.

6. Pattern Input/Output via USB

Customers can use USB disk for data transfer. USB disk supports DIR operation, which is easy for pattern management. For each directory, system supports operation of 400 patterns or sub-directory. There is no limitation of directory levels. Patterns in the formats of Binary, Ternary and Z-nary can be loaded.

7. Patch Embroidery

This function can set a patch point at the position of color code or stop code, and when the machine embroiders to the patch point, it will halt and move out frame for patching. After sticking a patch, user would press the start key to return the frame and continue embroidering.

8. Brake Adjustment

User can adjust the parameter of brake to let the main shaft stop at the correct position according to the characters of his own machines.

9. Save Start Point

This function can save the start point of each pattern, which saves the work of user to search the start point manually at embroidering the identical pattern.

10. Mechanical Maintenance and Debugging

This function is to easily judge the malfunctions at maintaining and debugging the machine, such as encoder testing, main shaft speed testing, machine parts testing and the main shaft stopping at any position, etc.

11. Multi-Language Support

Currently, the system supports the display in Chinese, English, Spanish and Turkish, Russian, French and many other languages.



12. Pattern Output

Patterns can be output and saved into USB disk. Adoption of TAJIMA's binary format enjoys the advantage of data transmitting through the World Wide Web (other formats may not be transmitted directly).

13. Repetition Embroidery

The user can increase embroidery productivity by using the function of repetition embroidery, which can also be used with cyclic embroidery.

14. Cyclic Embroidery

With this function, the machine can automatically return to the origin and start the same embroidery again when finishing the pattern one time. User also can increase productivity rapidly by combining this function with special pattern-making function or repetition embroidery function.

15. Pattern Compiling

(1) Compiling the Data of Selected Pattern to Generate New Pattern

Users can compile any pattern according to zoom ratio, rotate angle, normal repetition or partial repetition to generate a new pattern and save it to memory. The newly generated pattern can be used for embroidering, output or other operations.

(2) Compiling the Combined Pattern

After setting the combined pattern, the system can compile that pattern to generate a new one and save it to memory. The newly generated pattern can be used for embroidering, output or other operations.

16. Letter Pattern

There are 28 built-in font libraries. Users can make letter groups and change letter orders according to different tasks. This operation is vivid, simple and easy managing.

17. Pattern Edit (under developing)

18. Speed Adjustment

The highest speed for embroidery can be preset. During embroidery, speed may change automatically along with the change of needle interval.



19. Thread-trimming

Thread-trimming can be manually operated. The machine can trim the thread automatically at the end of embroidery process or at color-changing.

20. Thread-breakage Detection

In case of thread breakage or running-out of bobbin thread, the machine will stop and give warning by indicator.

21. Color-changing

At the color-changing point, user can either perform the color-changing manually or let the system do it automatically according to the preset order.

1.3 Technical Specifications

1. Maximum number of patterns saved in memory: 800
2. Memory capacity: 100 million stitches
3. Screen resolution ratio: 1280*800
4. Network port speed: 100Mbps
5. Supported method for data exchange: USB disk, network
6. Control precision: Minimum controllable stitch interval is 0.1mm
7. Stitch range: 0.1mm~12.7mm



Chapter 2 Embroidery Guide

2.1 Structure and Usage Instruction of Control Panel

I. Structure of Control Panel



1. Touching Panel

It adopts high-luminance LCD displayer and touching screen man-machine interaction interface.

2. Main USB Port

USB disk can be plugged for data input/output.

3. Buttons

Press the keys to main shaft jog ; start the embroidery, pause the embroidery.

II. Instructions on Touching Panel

This machine uses the touching panel as its input device. In order to extend the service life of the panel and to maintain its performance, please don't apply too much pressure on the screen during operation. Neither can user use the sharp or hard tools to click the screen.

III. Instructions on USB Disk

Please pay close attention to electrostatic phenomenon. Don't forget to discharge (we suggest you should touch the machine stand or frame to discharge the static) before plugging in/out the USB disk.

Pay attention to the direction of the USB disk at plug-in. Don't pull out the USB disk

when system loads data from or write data to it. If the USB disk is pulled out or the power is cut off during the data input/output, the data could be lost. In that case, please check the integrity of data in the USB disk and repair it before using.

Attention: During the process of initialization, if the power is cut off or the USB disk is pulled out, the USB disk may be damaged permanently.











2.2 Instruction of the Main Interface









No.	Icon	Name	Description	Reference Page
1		The state of infrared laser	Open, Close.	
		Wifi Connection Status	Wifi Connection Status (disconnected , connected)	
		Wireless Cloud Status	Wireless Cloud Status (disconnected , connected , successful registration)	
		Cyclic Embroidery	Cyclic embroidery is currently available. Press user parameter or specialist parameter to enter the parameter setting interface, where user can change the setting of cyclic embroidery.	









No.	Icon	Name	Description	Reference Page
1		Thread Breakage	This figure will appear when the machine stops due to the thread-breakage.	
		Assistant embroidery status/ lockstitch/special embroidery	Lockstitch , sequin, etc.	
		The main shaft stops at the right position (100°).	When the machine stops while the main shaft stops at the right position, you can do operations such as color-changing and frame-moving.	
		The main shaft hasn't stopped at the right position (100°).	When the machine stops and the main shaft haven't reached the right position, you need to turn the shaft to the 100° position manually by clicking .	
2		Pattern Display Area	The pattern for embroidery will be displayed in this area.	
3		Basic Pattern Data	Basic data of the current pattern will be displayed here.	
4		Pattern Management	Interface for pattern management	
		Parameter Setting	Interface for parameter setting	
		Color-changing Order Setting	Interface for color-changing order setting	
		Frame Selection and Position	Frame selection and position	
		Main Interface	Main interface	
		Embroidery Ready Status, Confirm the Embroidery	When the machine is in Ready Status, user can carry out preparation work of the embroidery, such as pattern selection, setting scale parameter, setting repetition parameters and so on. Click this key to confirm, and the machine will turn from Embroidery Ready Status into Embroidery	

No.	Icon	Name	Description	Reference Page
			Confirmation Status  .	
4		Embroidery Confirmation Status, Cancel the Embroidery	Currently, the machine is under Embroidery Confirmation Status, and user can start embroidery at any time. When the machine stops, user can click this key and confirm the cancelling of Embroidery Confirmation Status. And the machine will return to Embroidery Ready Status  from Embroidery Confirmation Status  .	
5		Back to Stop Point	After the machine stops, user can click Manual Frame-moving key to move the frame (like appliqué). Then user can click this key to have the frame return to the stop point of current design.	
		Back to Origin	After the machine stops, user can click this key to have the frame automatically return to the origin of the current design.	
		Idling	Used to move the frame to appointed position without embroidery	
		QR code	Scan QR code to view instructional videos.	
		Statistics	Display the interface of statistics.	
		Auto Color-changing, Auto Start	If the machine is set at Auto Color-changing, user should set the color-changing order in advance.	
		Auto Color-changing Manual Start	When user presses the start key for embroidery, no matter where the current needle rod locates, the machine will change the needle according to the set color-changing order and perform the embroidery. When encountering color-changing code, the machine will stop automatically and shift to the pointed needle position according to the auto	



No.	Icon	Name	Description	Reference Page
			color-changing order. If the machine is set at auto start, the machine will begin the embroidery automatically; if it is set at manual start, the user needs to press the start key for embroidery.	
5		Manual Color-changing, Manual Start	In this status, select the needle position with manual color-changing () to select the needle position and then press start key for embroiriery. When encountering color-changing code, the machine will stop automatically. Icon  appears, and the system awaits the manual color-changing At this moment, user needs to perform manual color-changing () to shift to the needed needle position, and press the start key for embroidery	
		Main Shaft Acceleration, Main Shaft Deceleration	For setting the main shaft acceleration/deceleration. When the main shaft reaches the highest/lowest speed, this key will be unavailable.	
6		Main Shaft Manual Adjustment	After stop, if the main shaft is not at the proper position  , press this key to adjust the main shaft to the right position 	Section2.3
		Manual Thread-trimming	After machine stop, user can click this key for the operation of manual thread-trimming .	Section2.3
		Manual Color-changing	When machine stops at correct position  , the operation is valid; press it to enter manual color-changing interface, where user can click corresponding needle position number to make color-changing.	Section2.3
		Other Function Operations	Press it to enter the interface for other function operations, such as statistic inquiry, frame origin setting, power-off recovery, soft limitation	Chapter 9

No.	Icon	Name	Description	Reference Page
			setting, machine authority management, touch screen calibration, and time management.	
7		Current Needle Position	This figure is for the actual needle position at present. 0 is for the invalid needle position.	
		Current Color-changing Times	The initial value is 1. After the embroidery starts, this value will add 1 at each finish of successful color-changing.	
		Color-changing Order	This order is the sequence of the needle rods for changing color. The 3D figure is for the current needle position.	
		Scale Up Pattern	Scale up pattern in the pattern display area. Hold pressing for 2s to shift to  .	
8		Manual Frame-moving	The frame will move along with the direction keys.	





No.	Icon	Name	Description	Reference Page
9		Pattern List	Display patterns by figures for users to select	
10		Pattern Sort	Pattern arrangement: Sort by pattern number , Sort by time .	
		Previous/Next Page	Display patterns in different pages	
11		Memory Pattern Preview	Used to check pattern details, scale up/down pattern, move or make analog display of pattern	
		Letter Pattern	Letter pattern and its parameter setting	
		U Disk Management	Press it to enter the U disk management interface for operations related to U disk.	
		Pattern Deletion	Used to delete selected patterns	
		Pattern Output	Used to transfer memory patterns to USB disk	
		Other Functions	Used to open other operation interfaces for memory patterns, such as pattern copy, deletion, combination, edit, etc.	
		Doodle Art Emb	Keep hand-drawn style.	
		Lettering Emb	10 languages, 100+ fonts.	
		Picture Emb	Picture automatically generated pattern.	
		Online pattern		
	Single/Multiple Selection	Shift between single selection mode and multiple selection mode		

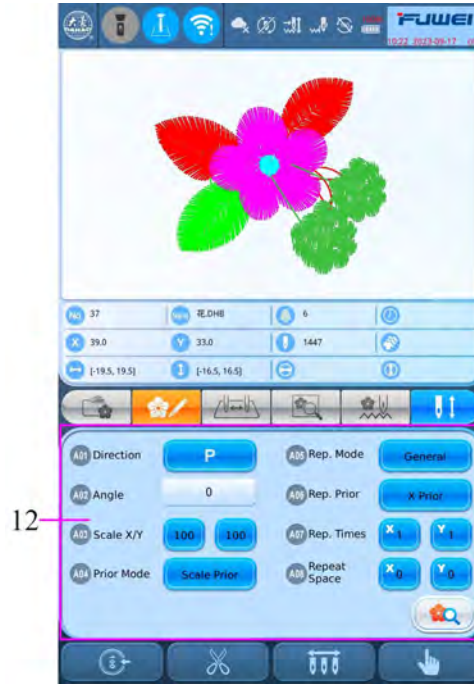









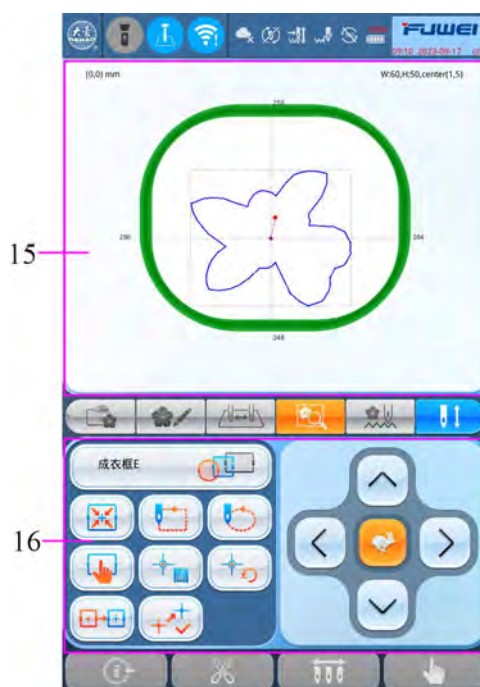



No.	Icon	Name	Description	Reference Page
12		Common Parameter Setting	User can adjust these parameters to control the final embroidery effect of the pattern.	
		Pattern Preview	Load the selected pattern, display the pattern data and draw up the pattern shape.	





No.	Icon	Name	Description	Reference Page
13		Current Operation Position	Set, insert or delete needle bar number here.	
		Color Lump Number List	Display the color lump number of the pattern	
		Needle Bar Number and Color	Display the needle bar number and needle bar thread color of the corresponding color lump	
		Move Up	Move up the color-changing list in order to select the color lump to be set	
		Insert Needle Bar Number	Press this key and then press needle bar number to insert it to the current needle bar number list	
		Delete Needle Bar Number	Delete the current needle bar number from the needle bar number list	
		Move Down	Move down the color-changing list in order to select the color lump to be set	
		Needle Bar Number Color Selection Area	Select the color for the selected needle bar number	
14		Repetition	Repeat the color-changing order	
		Patch Embroidery	Set as patch embroidery pattern	
		Needle Bar Color Setting	Set the needle bar color from default colors	





No.	Icon	Name	Description	Reference Page
15		Pattern Range Display		
16		Frame Type Selection		
		Position Pattern to the Center of the Frame		
		Move Frame along Pattern Outside		
		Move Frame along Pattern Outline		
		Frame Parameter Setting		
		Memory of Pattern Origin		
		Recovery of Pattern Origin		
		Recover frame position		
		Set Frame Origin		
		Manual Pattern Movement	<p>Switch between  and  can be activated by the switching key on the panel.</p> <p>High-speed Manual Frame-moving Status: When the machine stops, press the manual frame-moving keys to move the frame, and the frame will move in the high speed.</p> <p>Low-speed Manual Frame-moving Status: Different from the High-speed Manual Frame-moving Status, it is used for manual adjustment of the frame position.</p>	

2.3 Basic Procedure of Embroidery

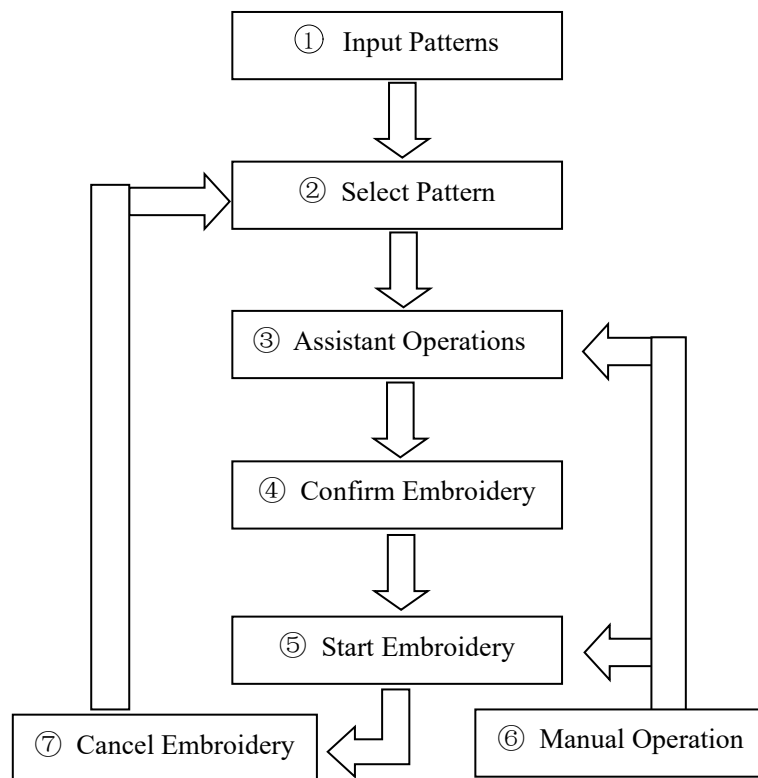
The machine carries out embroidery based on the patterns saved in memory. The following figure is the basic procedure of the embroidery:



I. Input Patterns



User can input patterns through network or USB disk. Only with  (successful registration) displayed, can it be possible to transmit patterns by network. For U disk operation, in pattern management interface, press  to enter U disk management interface.

II. Select Pattern

In pattern management interface, user can select needed pattern for embroidery.

III. Assistant Operations



After selecting the pattern for embroidery, user can make assistant operations according to need before embroidery.

1. Set repetition, rotation and scaling — press  to enter parameter management interface.
2. Set color-changing order — press  to enter color-changing setting interface.
3. Set patch embroidery — press  to enter color-changing setting interface





and set patch embroidery of the pattern according to hints.

4. For border inquiry, border idling, pattern outline —— press  to enter frame selection and position operation.

5. Locate pattern at frame center —— press  to enter frame selection and position operation. Please note this function is to locate pattern at the frame center set by soft limitation.



6. Set cyclic embroidery —— press  to enter other function operation. Press  to enter parameter management interface. Then press “Embroidery Assistant Parameters” and set cyclic embroidery according to hints.

IV. Confirm Embroidery

1. After assistant operations, press  to display a hint window, where user can select  to confirm and turn  (cancel embroidery) to  (confirm embroidery), which indicates the machine has entered Embroidery Ready Status.

If user selects , the machine will stay at Embroidery Cancel Status. At this time, the machine will not work even when user presses the start key. A hint window will display on the screen for user to confirm the embroidery.

2. Set Color-changing and Start Mode





Switch among  (Auto Color-changing, Auto Start),  (Auto Color-changing, Manual Start) and  (Manual Color-changing, Manual Start)

V. Manual Operation



1. Manual Thread-trimming:

When the machine stops, press  in the main interface to trim threads.

2. Manual Frame-Moving:

When the machine stops, press direction keys (, , , ) to move frame along the corresponding direction. Press the two neighboring keys at the



same time to move the frame in the direction of the angle bisector.  is the speed key for manual frame-moving. Press to shift between  (high speed) and  (low speed).



3. Manual Color-Changing

When the machine stops, press  in the main interface to enter manual color-changing interface. Then click the needle number for color-changing, and the machine head will automatically move to the corresponding needle position.

Please note: if the user wants to automatically save the order of the manual color-changing, user should operate it in the manual color-changing interface on the touch screen.

4. Adjust Main Shaft Manually

Usually, the main shaft needs to stop at 100° at needle/color-changing, frame-moving and beginning embroidery. User can manually turn the main shaft to 100° when it hasn't reached there. Press  in the main interface to carry out this function.

After the operation,  (not in position) will changing into  (in position).

5. Back to Origin

Press  to return the frame to origin.





6. Back to Stop Point

Press  to return the frame to stop point.

7. Positioned Idling



Use this function after embroidery confirmation. Positioned idling enables the machine to move to the appointed position without embroidering according to the user's requests. Press  to set the needle number, color-changing code and stop code for performing the positioned idling forward or backward.

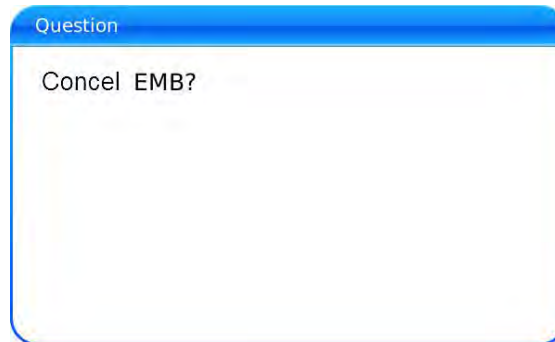

VI. Cancel Embroidery

When the machine stops, press  to display a hint window, where user can select  to turn  (embroidery confirmation) to  (cancel embroidery confirmation).



2.4 Normal Embroidery, Returning and Patching

In embroidery confirmation status ( is displayed), press  to start normal embroidery, and during embroidery, press  to stop embroidery.

When the machine stops, press  to return the frame back along with the original embroidery path; one press, one stitch back; hold pressing for 2s to return continuously, even without holding ; press  again to stop.

The purpose of returning is for patching, and when the machine stops returning, press  to start normal embroidery.

2.5 Embroidery Operation

When the machine stops, press  to start embroidery;

When the machine is embroidering, press  to stop embroidery.

2.6 Thread-Breakage Detection

Based on different working principles, thread-breakage detection devices have three types: thread take-up spring type, thread winding wheel (chopper wheel) type and mixed type.





For thread take-up spring type, it detects the thread-breakage by searching connection of take-up spring and contact point. When thread breaks, the spring will close to the contact point. In normal condition, this detecting type is sensitive to the face thread breakage, but can hardly detect bobbin thread run-out. In case you change the embroidery thread, or thread tension changes, you need to adjust spring pressure between the take-up spring and contact point. When the spring pressure is too large, there will be False Alarm; when the spring pressure is too small, there will be Missing Alarm.

For thread winding wheel type, it judges thread-breakage by detecting the winding wheel angle. It is very sensitive in case of face thread breakage; in most cases of bobbin thread run-out, the consumption of face thread will reduce, as a result, system will judge by statistic method and send out warning. Though it can almost avoid False Positive, it is not as sensitive as the spring-type.





For the mixed type method, the two can complement each other with their advantages, which results in sensitive and stabilized detecting effect.

2.7 Working Status

There are three working statuses:

1. Embroidery Ready Status  —— preset parameters, choose embroidery patterns and make other preparation work for embroidery.
2. Embroidery Confirmation status  —— confirm the parameter settings to enter the quasi-running status.
3. Embroidery Running Status  —— embroidery.





Shift among these three working statuses:

In embroidery ready status ( is displayed in the main interface), if users have selected pattern and related parameters, press  and then press  to confirm, and the system will enter embroidery confirmation status ( is displayed in the main interface). At this time, press start key to start embroidery, when the machine is under



embroidery running status ( is displayed in the main interface).

In embroidery running status ( is displayed in the main interface), press stop key to stop embroidery and return to embroidery confirmation status, where user can press start key again to enter embroidery running status.

In embroidery confirmation status ( is displayed in the main interface), press  and then press  to confirm, user can release the confirmation status and return to embroidery ready status ( is displayed in the main interface).



Chapter 3 U Disk Management

In U disk management interface, user can input patterns from U disk to machine, and vice versa; meanwhile, user can undertake some common U disk managements, like erasing file or directory, initializing the disk, etc. User can save patterns data under different directories of the U disk based on different types. Patterns formats like DSB, DST and DSZ can be read by the system. For data output, patterns will be saved in the U disk as DSB format.

3.1 Select U Disk

Since the system supports several storage devices, user need select the U disk for operation.

1. Press  in pattern management interface.
2. System will display “Select U Disk” window, where user need select U disk by pressing corresponding icon.



In this window all the storage devices will be displayed. Their information includes the icon, words and numbers. The icon is the device type. Icon  indicates U disk. The words are the label of the U disk (if the U disk has no label, the default letter will be used), and the number refers to the U disk's digital symbol.

3. Enter U disk operation interface.



No.	Icon	Name	Description
1		File List	Display the pattern files and file folders within the U disk in icons. It's used to select files.
2		Page Information	The current page number and total page number
		Back to Upper Level	Return to upper level
3		Basic Pattern Data	Display the basic data of current pattern
4		Pattern Preview	Load the selected pattern. Check its details, scale up/down the pattern, and move or make analog display of the pattern.
		Create Directory	Create new file folder
		Pattern Input	Import the patterns in the U disk to memory.
		Deletion	Delete the file or file folder
		Formatting U Disk	Formatting the U disk
		Single/Multiple Selection	Shift between single selection mode and multiple selection mode
		Exit	Exit U disk management.



3.2 Pattern Preview

1. In the U disk management interface, press the pattern for preview.



Pattern files and directories are shown in figure in the list. One page of the list contains 8 items. If the amount of the object within the current directory is more than 8, the object list will be displayed in many pages. Click the key to turn page and look for patterns in another page. The selected object has a different frame and background color.

2. Press 



The system loads the data from the U disk and user can check details of the pattern, scaleup/down the pattern, move or make analog display of the pattern. For more information, please refer to section 6.3.

3.3 Pattern Input

To input patterns within the U disk to the machine's memory, user need select the pattern files to be inputted, and then input the number and name for the patterns to be saved in memory.

1. Select pattern files of the U disk;
2. Press  and the system will require input of pattern number and name;



3. Input the pattern number and name to be saved in memory;

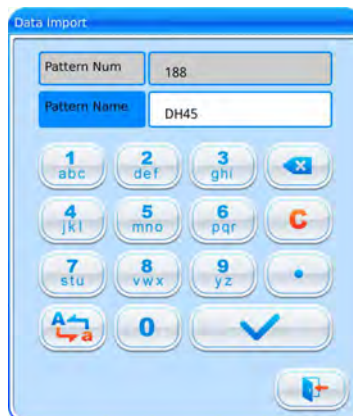



The system provides the minimum available pattern number as the default value. User can use the keypad below to change the number.

4. Press  to confirm;
5. The system will save the pattern data from the U disk to the memory.

3.4 Directory Operation

1. Enter directory:

Double click the icon of the object directory to enter it, and the system will load the item list of the directory and refresh the display interface.

2. Return to Upper Level:

Press  to return to the upper level of directory and refresh the display interface.

3.5 Create a New Directory in the Current Directory

1. Press 
2. Input the new directory name

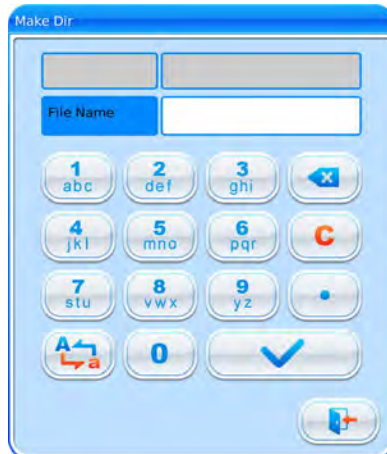

3. Press 

System will create the corresponding directory in the U disk and refresh the current object list.

3.6 Delete Objects from U Disk (including pattern file and directory)

1. Select objects to be deleted;

2. Press  to delete;



3. System will ask user to confirm the deletion.

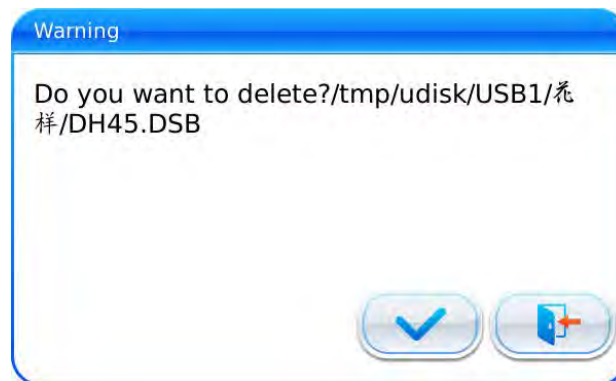

Note:

If the user wants to delete a directory, the system will delete all the files and sub-directories within this directory. In case of “Read Only” or “U Disk Write Protection”, the file will be unable to delete.



3.7 Formatting U Disk

1. Select the U disk for formatting;
2. Press  to start formatting;

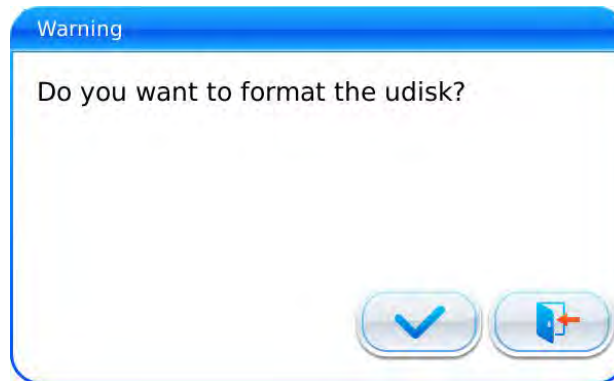

3. Press  to confirm



System will begin to format the disk and return automatically to U disk management interface after finishing formatting.

Note: system will format the U disk according to DOS format.



Chapter 4 Common Parameters and Color-Changing Order

In this system each pattern has its own settings of the normal parameters (like scale and repetition) and color-changing order. When a new pattern is selected, the corresponding settings of normal parameters and color-changing order will become effective.

In this chapter, we will discuss the setting of the most frequently used parameters and color-changing order, in parameter setting interface () and needle bar color-changing order setting interface ()

Since this system supports multi-task operation, user can set and modify the normal parameters and color-changing order of the patterns that are not embroidered at present. User can enter these operations via other operation interface under pattern management (see Chapter 6).

4.1 Settings of Common Parameters

These common parameters include: “Direction”, “Angle”, “Scale X/Y”, “Prior Mode”, “Rep. Mode”, “Rep. Order”, “Rep. Times”, and “Rep. Interval”. User can control the final embroidery results by adjusting these parameters.

Press  to enter parameter setting interface:

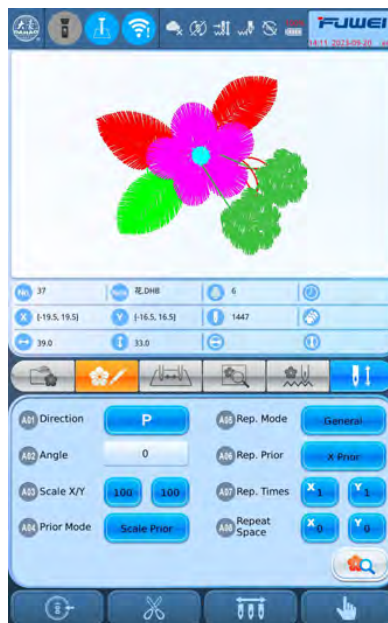



The way for setting the parameter is similar to each other. This chapter will explain how to set the “X/Y Scale” as an example and give the definitions of other parameters (refer to 4.1.1 for setting method).

4.1.1. Settings of X-Y Scale

This parameter controls the scaling percentages on X (horizontal) and Y (vertical) direction, so as to scale up/down the patterns.

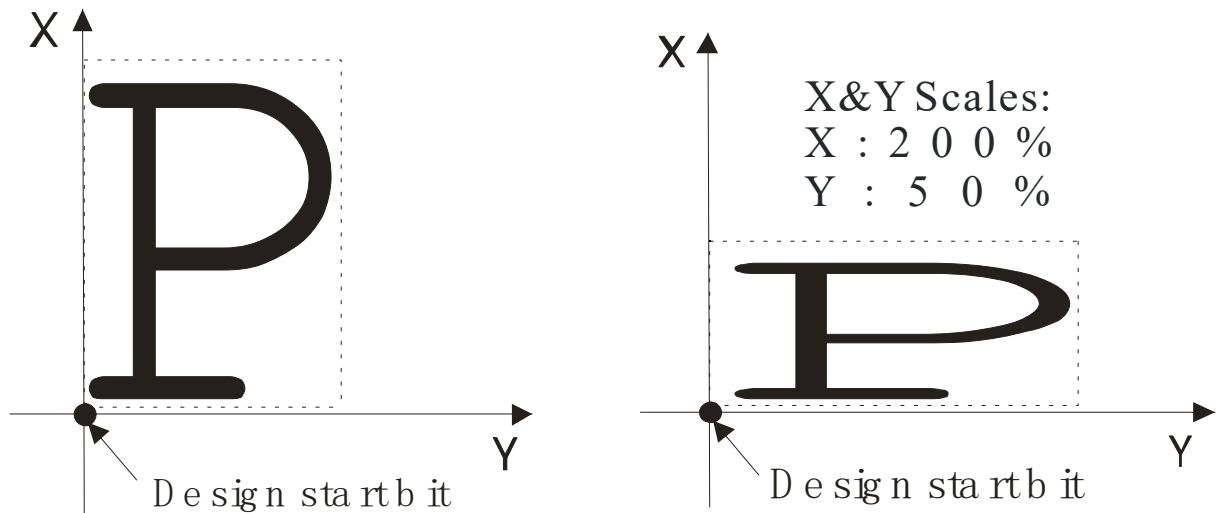

1. Press the function item of “Scale X/Y”

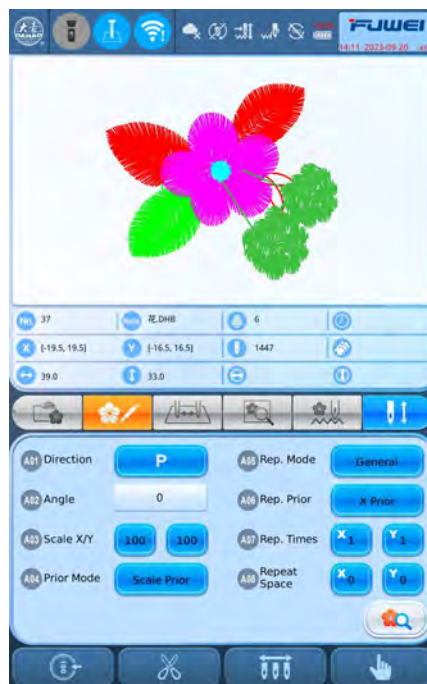

System will display independently the modification windows for X Scale and Y Scale for users to set respectively.

2. Adjusting X-Y Scales

User can press number pad to modify the scaling rate at X direction, press to cancel the last input digit and press to clear the input number.



3. Press to save the modification

The modification method of Y Scale is the same with that of X Scale.

4.1.2. Settings of Rotate Angle

User can rotate patterns to a certain angle by this parameter.

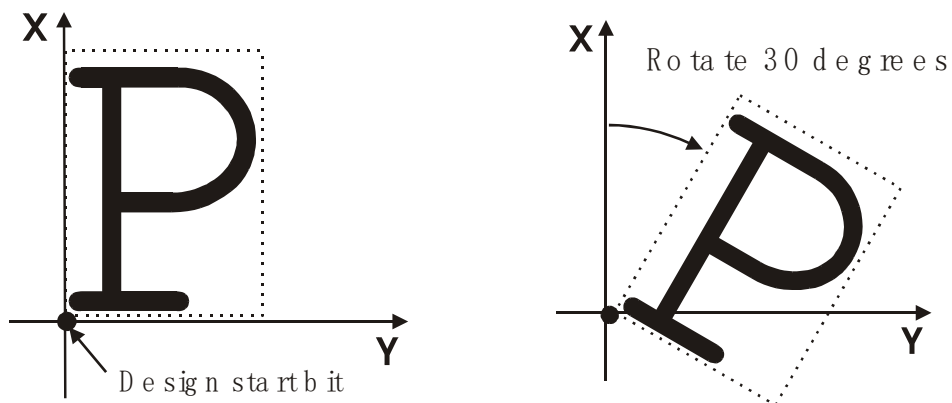

4.1.3. Pattern Direction

图案方向	p	q	d	o	q	o	b	p	p
刺绣结果	F	L	F	π	7	π	E	π	F



4.1.4. Prior Mode

There are two modes: “rotation prior to scaling” and “scaling prior to rotation”. When user has set the parameters “Scale X/Y” and “Rotate Angle”, the patterns will rotate first and then scale up/down, if “rotation prior to scaling” mode is selected. Otherwise it will scale up/down first and then rotate.

4.1.5. Rep. Mode

There are two repetition modes: normal and partial.

4.1.6. Rep. Order

There are two modes: X first and Y first.

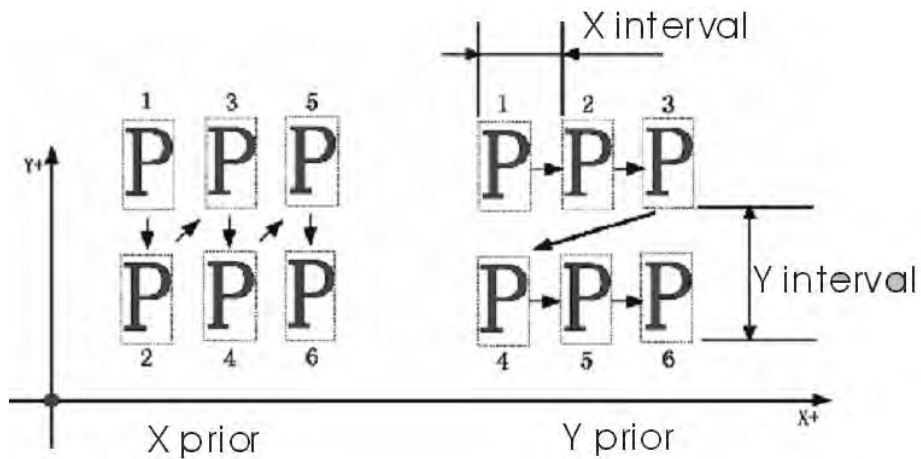

4.1.7. X-Y Rep. Times

X repetition times represent the number of columns, while Y repetition times the number of lines; as shown in the above picture, X repetition times are 3 and Y repetition times is 2. The largest set value is 99*99.





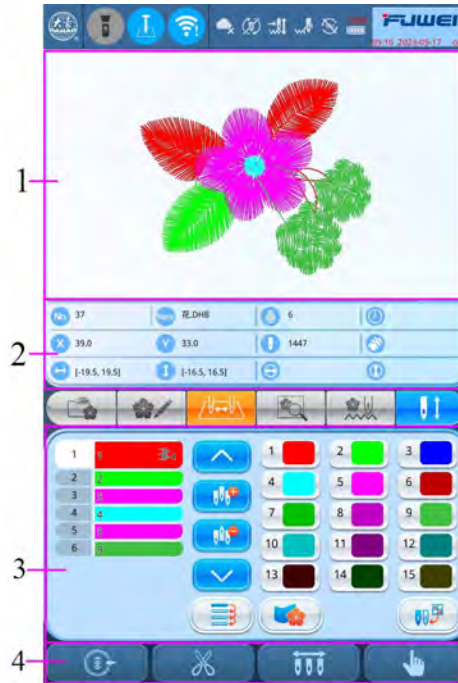

4.1.8. X-Y Rep. Interval

The above picture has explained the meaning.





4.2 Settings of Color-changing Order

4.2.1. Color-changing Interface



No.	Icon	Name	Description
1		Pattern Display Area	Display the pattern according to real-time setting of color-changing order, for the preview of the result of color-changing.
2		Basic Pattern Data	Display the basic data of the pattern
3		Current Operation Position	User can set, insert or delete needle bar number in current position.
3		Color Lump Number List	Display the number of the color lumps of the pattern
		Needle Bar Number and Color	Display the needle bar number and thread color of each corresponding color lump
		Move Up	Move upward the color-changing list to select the color lump for setting
		Insert Needle Bar Number	Click this key and a needle number to insert it in the current list of needle list.
		Delete Needle Bar Number	Delete the needle number of the current operation position in the needle list.
		Move Down	Move downward the color-changing







No.	Icon	Name	Description
			list to select the color lump for setting
4		Color Selection Area	Select the color for the needle bar number to be set
5		Repetition	Repeat color-changing order
		Patch Embroidery	Set the patch embroidery of the pattern
		Set Needle Bar Color	Select default colors to set the color of each needle bar

The pattern display area displays the pattern under color-changing setting. After changing the color-changing order, the display will be renewed at same time to show the modification effect.





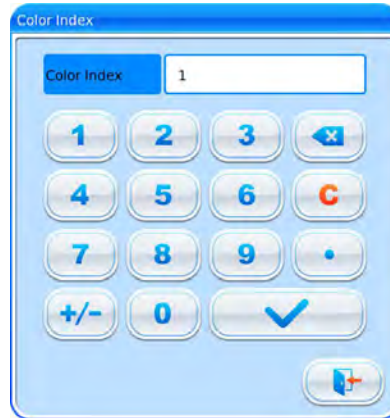

Color-changing order display area shows color lump numbers, needle bar numbers and needle bar colors.

Pattern display can be in parallel with the setting, insertion and deletion of needle bar number, which means that users can set and change the color-changing order along with the display.

4.2.2. Settings of Color-Changing Order



1. Press  to enter color-changing setting interface.
 2. Input the needle bar numbers in order in the needle bar number selection area. The pattern display and the color list will be refreshed after each input.
 3. Press   to check whether the inputted color-changing order is correct.
- Or press **2** to “Color Index” interface, input the color block number you want to view, and then press  to jump to the color block.



4. To change a certain needle bar number, press   to move to the item to be modified and then press the new needle bar number.
5. To insert a new needle bar number, press   to move to the position below the position to be inserted, and then  to insert the needle bar number.
6. Press  to delete a needle bar number.



4.2.3. Set Needle Bar Color

To make the display effect close to the actual embroidery effect, this system allows settings of color for each needle bar and such settings can be saved together with the color-changing order of the pattern.

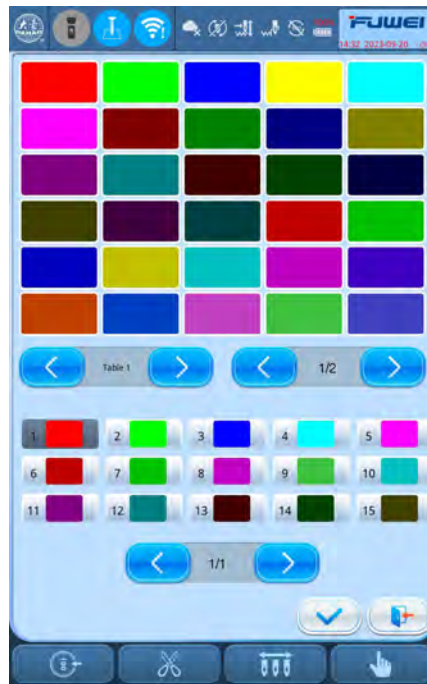
1. Press  to enter color-changing setting interface.
2. Press  to enter needle bar color setting interface.





45 default colors for selection in the setting interface

- To set the needle bar color, select the needle bar first and then select the color from the 45 default color lumps. The corresponding color of the needle bar button will be refreshed.
- Press  to save the settings and return to the color-changing order setting interface; or press  to quit setting without saving and return to color-changing order setting interface.

Chapter 5 Settings of Embroidery Parameters

Parameters are grouped according to different functions (see Appendix 1 Parameter List)

Press  in the main interface and press  (for user) or  (for specialist) to enter parameter setting interface.



1. After system enters parameter setting interface, user can select the parameter for setting.





Note:

- the number, name and current value of each parameter are displayed in the parameter list window.
- Enter parameter management interface, press category selection  to check related parameters quickly.

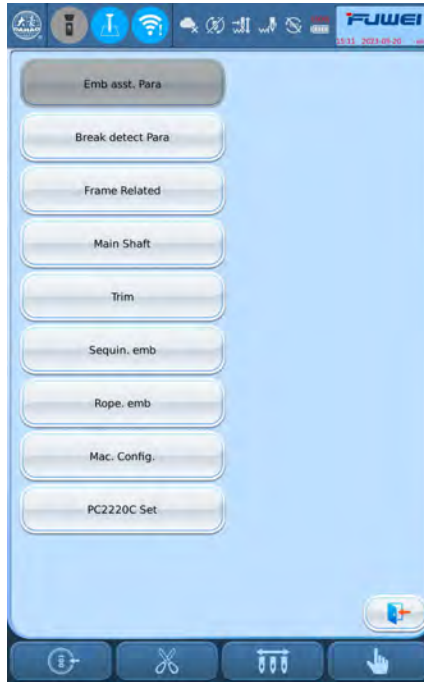

5.1 Procedure for Setting General Parameters

The setting procedure is similar for each general parameter. You can follow the guide of this section to set all parameters.

1. Select Parameter Type

User can use the keys at the bottom of the screen (parameter type key and page key) to look for the parameter.

If you want to modify the number of needles whose parameter number is D01, press  to find machine configuration parameter and the its parameter list will be displayed.



2. Press the parameter to be set and input the new value by the number keys.

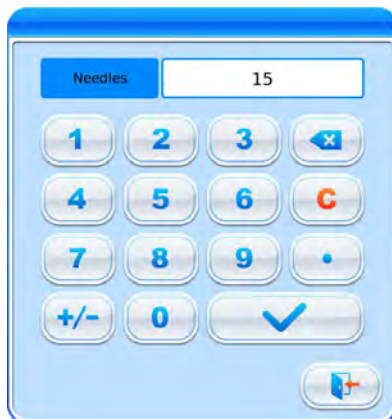

3. Press to finish the setting.

5.2 Instruction on Some Functions within General Parameters

There are brief descriptions of parameters in the appendix 1. Here, we will introduce some functions mainly used in embroidery.

5.2.1. Cyclic Embroidery Function

This function is to increase the embroidery productivity.

When the parameter “To Do Cyclic Emb.” is set as “Yes”, the cyclic embroidery function is activated and the icon will appear in the main interface. If this function is activated, the machine will automatically embroider the patterns again without





any operation when completing it.

Usually, cyclic embroidery should accompany repetition embroidery and specially made patterns, and the parameter “Auto Origin” should be also set as “Yes”. Thus when the machine is embroidering the back fabric, the front one can be replaced. After embroidering the patterns, the frame will automatically return to the start point and the machine will automatically embroider the front fabric again and at this time it’s possible for user to replace the back one.

5.2.2. Brake Adjustment (A Must for New Machine)

This function is to adjust the control parameters for braking, so as to fit machines with different mechanical characters, which is also able to change with the machine running. Thus this function can help the machinery parts to work better with the computer. The function depends on the parameters “Set Brake Para”.

“Set Brake Para” is to adjust the stop position of the main shaft. When the main shaft often stops at the position below 100 degree, the user can increase the parameter value. When the main shaft often stops at the position over 100 degree, the user can decrease the parameter value. Thus the user can adjust the value to let the main shaft stop close to 100 degree. The value can be set between 0 and 30.

After adjusting this parameter, the user can click the task swift key on the panel to return to the main interface. Click  and  to make the adjustment and check the effects of the parameter adjustment. If the user is not satisfied with the effects, he can press the swift key on the panel to return to the parameter setting interface, where he can adjust the parameter setting again. Close the parameter setting interface in the end.

Chapter 6 Memory Pattern Management

Memory pattern management includes selection of embroidery patterns, settings of patterns, change of patterns and operations for creating patterns.

6.1 Memory Pattern Management Interface and Other Memory Pattern Operation Interfaces











Press  to enter memory pattern management interface.

The memory patterns management interface contains: patterns image display area, navigation and pagination area, information area and management operation area. The patterns image display area can show 8 patterns at most. If the total number of the patterns is beyond 8, more pages will be needed. Navigation and pagination area can help switch to the patternsated page. The management operation area is to preview patterns and set their order.







No.	Icon	Name	Description
1		Pattern Display Area	Display the pattern files in memory by icons. It's mainly for selection.
2		Pattern sort	Pattern arrangement: Sort by pattern

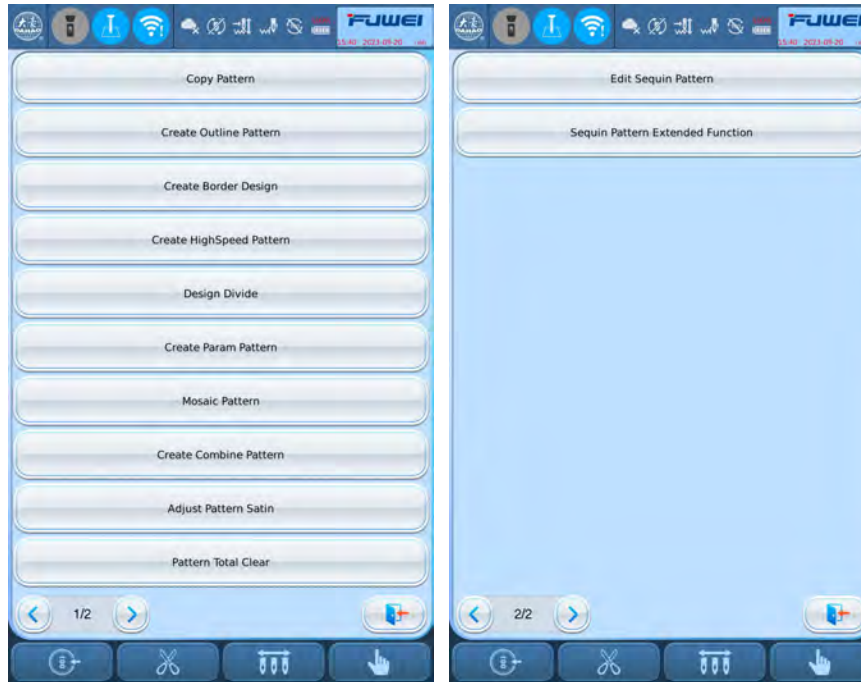

No.	Icon	Name	Description
			number  、Sort by time  .
2		Previous/Next Page	Used to shift to appointed page number
3		Information Area	Display the detailed information of the selected pattern and the memory information.
4		Memory Pattern Preview	Used to check pattern details, scale up/down pattern, move or make analog display of pattern
		Letter Pattern	Letter pattern and its parameter setting
		U Disk Management	Press it to enter the U disk management interface for operations related to U disk.
		Pattern Deletion	Used to delete selected patterns
		Pattern Output	Used to transfer memory patterns to USB disk
		Other Functions	Used to open other operation interfaces for memory patterns, such as pattern copy, deletion, combination, edit, etc.
		Single/Multiple Selection Shift	Shift between single selection and multiple selections.

Press  to enter the interface for other operations of memory pattern (to deal with any single pattern, user need select the pattern first).



In this interface, press each operation to enter the corresponding interface. Please read the following paragraphs for detailed explanation. Press  or  to turn page, and press  to return to memory pattern management interface.

6.2 Select Pattern for Embroidery





1. Press  to enter memory pattern management interface.
2. Select the pattern in the memory pattern image display area.

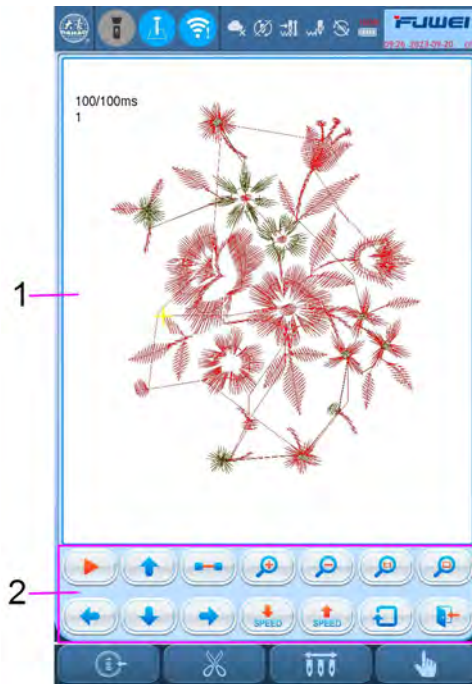













6.3 Memory Pattern Preview

The selected pattern can be previewed in the memory pattern preview interface to check more details.





No.	Icon	Name	Description
1		Pattern Preview Area	Display the pattern in the appointed method and speed
2		Draw/Pause Switch	Shift between drawing pattern and pausing display
		Move up	Move the pattern upwards
		Single Step Display	Draw the pattern by drawing single steps
		Scale up	Enlarge the pattern in the preview area
		Scale down	Reduce the pattern in the preview area
		Actual Display	Display the pattern in the actual size. So the size of the pattern on the screen is the actual size of the pattern after embroidery.
		Display to the Size of the Window	Display the pattern accordint to the size of the pattern preview area.
		Move left	Move the pattern leftward
		Move down	Move the pattern downward

No.	Icon	Name	Description
2		Move right	Move the pattern rightward
		Deceleration	Lower the display speed of patterns
		Acceleration	Fasten the display speed of patterns
		Redraw	Redisplay the selected pattern
		Quit	Quit the operation in pattern preview interface

1. Press  to enter memory pattern management interface.
2. Select a pattern in the memory pattern image display area.
3. Press  to open memory pattern preview interface.
4. Press     to control the size of the pattern display. Press     to control the display position. Press   to control display speed. Press  to shift to the pause status, where the single step of pattern can be displayed. Press  to redisplay the selected pattern.

6.4 Pattern Output

User can transfer the pattern data in memory to U disk.

1. Press  to enter memory pattern management interface
2. Select the memory patterns to be outputted
3. Press 



4. System will display the window to “Select U disk” and press to make the selection.



4. Input the pattern name saved in the U disk.

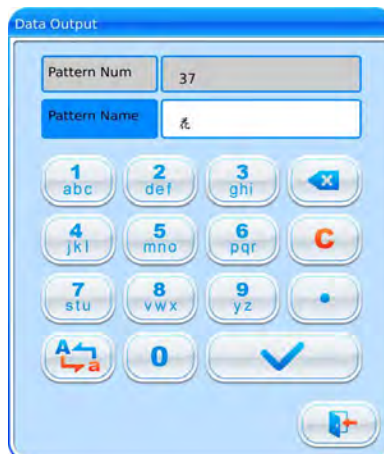



The system provides the minimum available pattern number as the default value. User can use the keypad below to change the number.

5. Press  of the completion hint.



6. Press  to return to pattern management interface.



6.5 Copy the Memory Pattern

1. Press  to enter memory pattern management interface.
2. Select a pattern in the memory pattern image display area.
3. Press  to enter memory operation selection interface.
4. Click “Copy Pattern” to enter its operation interface. The system will automatically provide the smallest available pattern number and default pattern name. If the user doesn’t want to change them, please press .
5. To input a new pattern number, click “New Pattern number” and input the new number in the pop-up window.



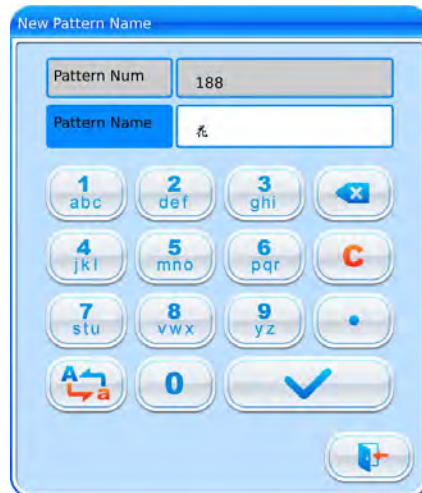



6. To change the new pattern name, click “New Pattern name” and input the new name in the pop-up window.



7. Press  to copy the pattern and return to pattern operation selection interface. Press  to cancel the copy operation and return to pattern operation selection interface.





6.6 Create Outline Pattern

This operation can generate a new pattern based on the outline of the designated pattern.

1. Press  to enter memory pattern management interface.
2. Select a pattern in the memory pattern image display area.
3. Press  to enter memory operation selection interface.
4. Press “Create Outline Pattern” to enter the operation interface.
5. User can press to input new pattern number and name instead of default ones.
6. Press  to create the outline pattern and return to pattern operation selection interface. Press  to quit the creating operation and return to pattern operation selection interface.



6.7 Create High-speed Pattern

This function can be used to divide long stitch into short ones, so as to prevent speed reduction due to long stitches.

1. Press  to enter memory pattern management interface.
2. Select a pattern in the memory pattern image display area.
3. Press  to enter memory operation selection interface.
4. Press “Create High-speed Pattern” to enter the operation interface.
5. User can press to input new pattern number and name instead of default ones.
6. Press  to create the high-speed pattern and return to pattern operation selection interface. Press  to quit the creating operation and return to pattern operation selection interface.

6.8 Divide Pattern

This operation is to divide one pattern into two new patterns.

1. Press  to enter memory pattern management interface.
2. Select a pattern in the memory pattern image display area.
3. Press  to enter memory operation selection interface.
4. Press “Divide Pattern” to enter the operation interface.
5. User can press to input new pattern number and name instead of default ones.
6. Press “Divide Stitch” to input the stitch number of the division position.





7. Press  to divide the pattern into two new patterns and return to pattern





operation selection interface. Press  to quit the dividing operation and return to pattern operation selection interface.

6.9 Create Parameter Pattern

This operation is to create a new pattern from the selected pattern together with the settings of its common parameters and color-changing order.



1. Press  to enter memory pattern management interface.
2. Select a pattern in the memory pattern image display area.
3. Press  to enter memory operation selection interface.
4. Press “Create Parameter Pattern” to enter the operation interface.





5. User can press to input new pattern number and name instead of default ones.
6. Press  to create the parameter pattern and return to pattern operation selection interface. Press  to quit the creating operation and return to pattern operation selection interface.

6.10 Mosaic Pattern

This operation is to combine two patterns into one new pattern. The interval of patterns refers to the distance between the end of the first pattern and the start of the second pattern.

1. Press  to enter memory pattern management interface.
2. Select the two patterns to be combined and record their pattern numbers.
3. Press  to enter memory operation selection interface.
4. Press “Mosaic Pattern” to enter the operation interface.
5. User can press to input new pattern number and name instead of default ones.
6. Press “X Interval” to input the value. Press “Y Interval” to input the value.





7. Press  to combine patterns and return to pattern operation selection interface. Press  to quit the combining operation and return to pattern operation selection interface.



6.11 Create Combined Pattern



The combined pattern means a pattern group combined from several certain (less than 99) memory patterns after setting their parameters. The combined pattern is set as automatic continuous embroidery. To embroider a combined pattern, user need return to the memory pattern management interface after creating or editing the combined pattern, where user can select the combined pattern, and then after embroidery confirmation, press start to embroider.

1. Press  to enter memory pattern management interface.
2. To edit existing combined patterns, select a combined pattern; to create a new combined pattern, just follow the instructions below.
3. Press  to enter memory operation selection interface.
4. Press “Create Combined Pattern” to enter the operation interface.

The combined ID shows the current pattern number and how many patterns the combined pattern is composed of. Display form is “pattern number (the total amount of patterns)”.



5. Set the parameters of the first pattern, including pattern number, scaling ratio, rotating angle, pattern direction and priority mode. Please refer to Chapter 4 for details of the settings.

6. Press  to set several patterns for packing. And press  to go back to change the parameters of combined patterns.

If the current pattern is not the first of the combined pattern, user need set the interval between it and the first pattern. Please refer to Chapter 4 for details of inputting parameters.



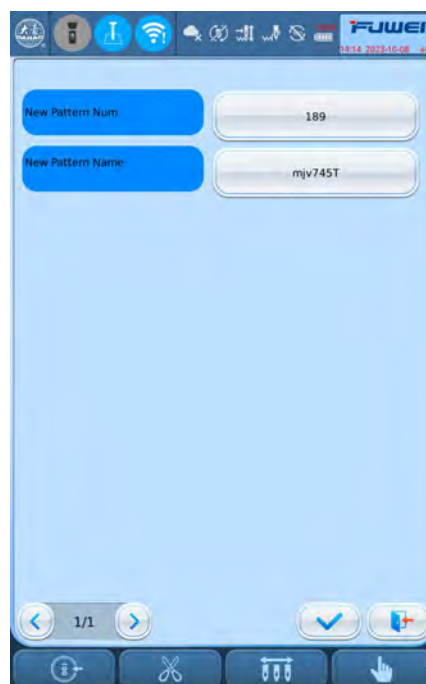

7. Press  to enter the operation interface.







The system will hint user to input the new pattern number and the new pattern name.



- Press  to save the combined pattern and return to pattern operation selection interface. Press  to quit saving and return to pattern operation selection interface.

6.12 Satin Stitch Adjustment

This operation is to adjust the satin width in the design according to the need.

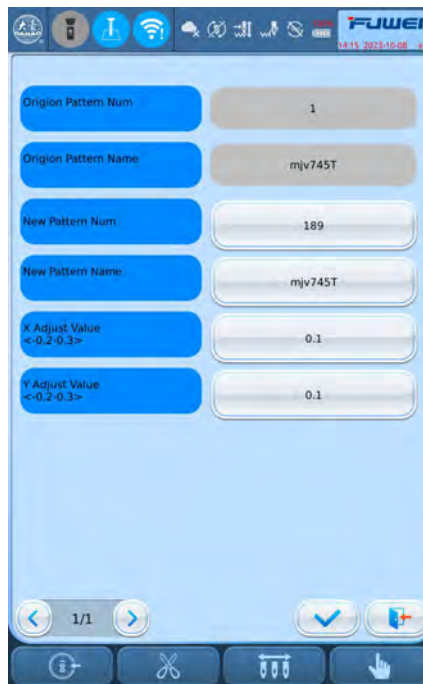
- Press  to enter memory pattern management interface.
- Select a pattern in the memory pattern image display area.
- Press  to enter memory operation selection interface.
- Press “Satin Stitch Adjustment” to enter the operation interface.



- User can press to input new pattern number and name instead of default ones.
- Press “X Adjust Value” and “Y Adjust Value” to input the value respectively.
- Press  to make the satin stitch adjustment and return to pattern operation selection interface. Press  to quit the adjusting operation and return to pattern operation selection interface.

Chapter 7 Letter Pattern Operation

System can generate letter pattern based on the built-in font libraries.

7.1 Enter Main Interface for Letter Embroidery

Press  in the pattern management interface to enter the main interface for letter embroidery.

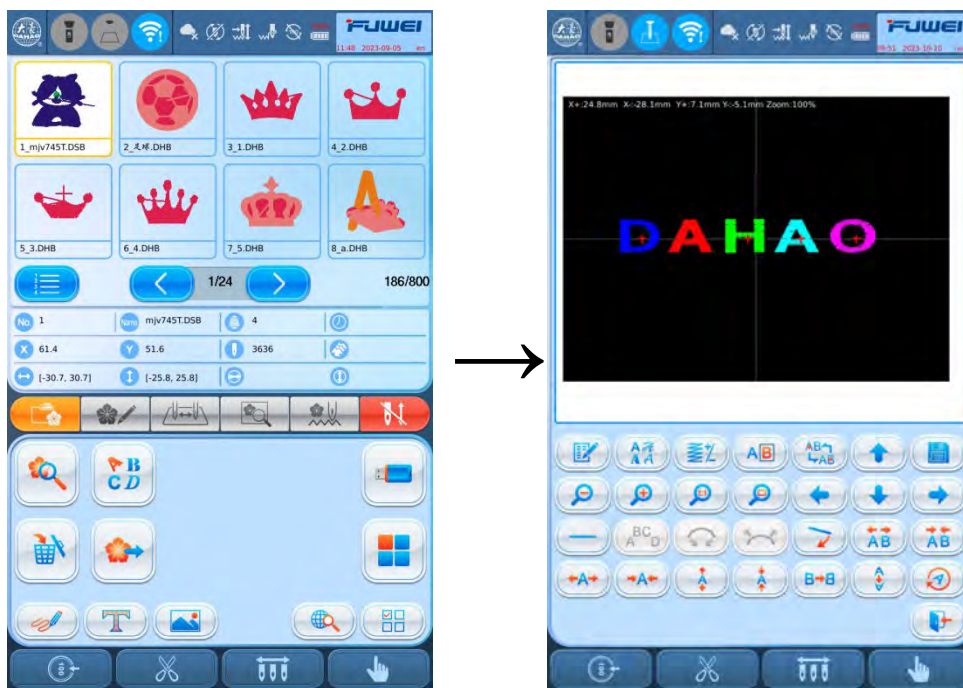

7.2 Input Letter String for Embroidery

Press  in the main interface for letter embroidery to enter letter string input interface.

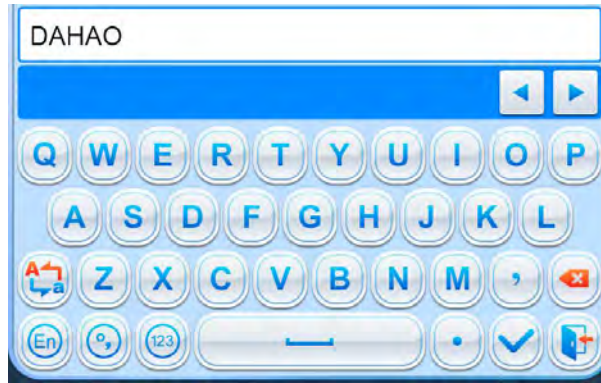

The upside of the window is the display area and the downside is the operation area. After inputting the letter string, press  to save.

7.3 Adjust Letter Pattern

1. Letter Pattern Adjustment Interface



There are 4 rows of operation keys in the interface, the first two rows are the file and view functions keys, the third row are keys for adjusting letter arrangement, and the fourth row are keys for adjusting letter string. In the middle of the interface is the letter pattern display area.

Generally, user should set the parameters, such as whole arrangement method, rotate angle and letter interval of the letter string; then select certain letter to adjust the its arrangement

parameters.

Letter patten display window: the crosses in the centre are the coordinates and the intersection represents the origin (0, 0). The letter will be arranged around the origin automatically.

2. Keys for Adjusting Selected Letters



“Letter String”: edit letter string.



“Change Font”: change the font of selected letters. Press this key to display a dialog box, where user can select a desired font and confirm it.



“Color-changing Shift”: set or cancel color-changing before the selected letter.



“Selection Shift”: shift among selected letters. A letter must be selected before any edit. If a red “+” appears on a letter, it means the letter is selected, such as . The system will select all letters as default. Press this key to select the first letter, and press it again to select the second one, and so on. After selecting the last letter, press this key again to select all letters.



“Increase Width”: increase width of selected letter.



“Reduce Width”: reduce width of selected letter.



“Increase Height”: increase height of selected letter.



“Reduce Height”: reduce height of selected letter.



“Horizontal Overturn”: overturn the selected letter horizontally.



“Vertical Overturn”: overturn the selected letter vertically.



“Clockwise Rotation”: use the letter as centre (“+” in the centre of letter), and rotate the selected letter clockwise.

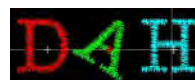

3. View and File Operation



 “Letter Density”: adjust the density of the letter string. Press this key to display the density dialog box, where user can set stitch form, increase or decrease density.



 “Stitch Form”: show/hide the stitch form. Hiding the stitch form can improve operation speed.







 “Increase Density”: increase the satin stitch density of the created letter pattern.

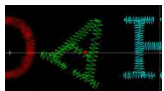



 “Reduce Density”: reduce satin stitch density of the created letter pattern.



    “Left”, “Right”, “Up” and “Down”: move letter pattern toward each direction.

 “Reduce”: reduce to the display window of letter pattern.

 “Enlarge”: enlarge to show the detailed part of the letter pattern.

 “Actual”: show the letter pattern in the actual size. At this time, the size of pattern in interface is equal to actual size.

 “Center”: scale up/down the view, so as to show the whole pattern for checking.

 “Save”: it is used for saving the edited letter pattern. After pressing this key, the



system will display the window for user to input the pattern number and name. According to need, change the pattern name and number (the number is not recommended to be changed), then press confirmation key to start saving.

 “Exit”: quit from “Create Letter Pattern”.

4. Keys for Adjusting Whole Arrangement

If you adjust the parameters for whole rank after the edition of the individual letter, the edition of the individual letter will be probably replaced.



 “Horizontal”: rank the letters horizontally 

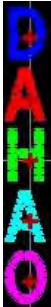

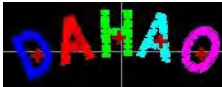
Press this key to shift among “horizontal”, “vertical”, “up arc”, and “down arc”. Only in case of “up arc” and “down arc” can “fix letter direction”, “increase radian” and “decrease radian” be adjusted.

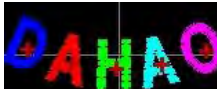
 “Vertical”: rank letters vertically 

 “Up Arc”: rank letters in arc bending upwards 

 “Down Arc”: rank letters in arc bending downwards 

 “Fix Letter Direction”: when user ranks the letters in arc, the letter angle will not change along with the position of arc, but fix at a certain angle 

 “Increase Radian”: when user ranks the letters in arc, this key can enlarge the radian of the reference arc 



“Reduce Radian”: when user ranks the letters in arc, this key can reduce the radian

of the reference arc



“Whole Clockwise Rotate”: rotate the whole letter string clockwise





“Enlarge Letter Interval”: increase the interval between letters



“Reduce Letter Interval”: reduce the interval between letters



7.4 Save Letter Pattern

After finishing the letter pattern edit, user can press  to display a window for user to input pattern number and name, and then press  again to save.

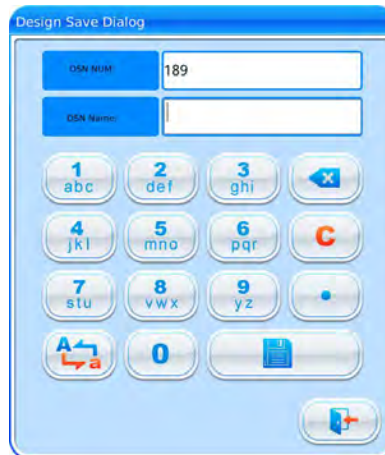

After saving, system will return to the main interface for letter embroidery.

If there is no need to edit letter pattern, press  to quit and the following hint will be displayed.



Press  to save or press  to cancel saving, and return to the pattern management interface.









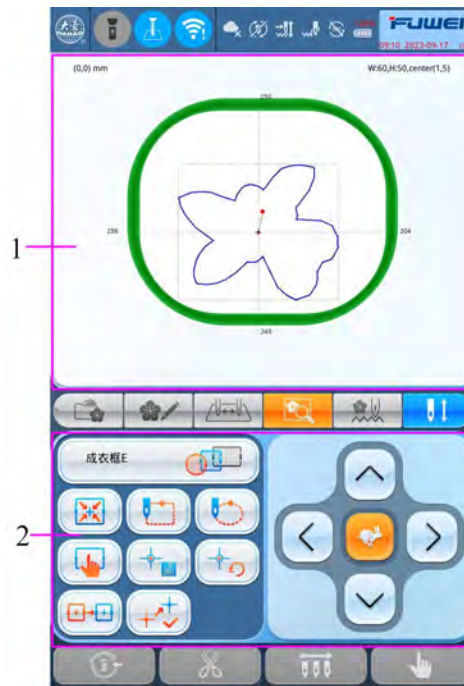

Chapter 8 Assistant Operation



User can perform some common assistant operations by pressing keys.

8.1 Frame Selection

User can press "" key to enter the interface for frame selection and position.





No.	Icon	Name
1		Pattern Range Display
2		Frame Type Selection
		Position Pattern to the Center of the Frame
		Move Frame along Pattern Outside
		Move Frame along Pattern Outline
		Frame Parameter Setting
		Memory of Pattern Origin
		Recovery of Pattern Origin

No.	Icon	Name
2		Set Frame Origin
		Recover frame position
		Manual Pattern Movement

8.2 Set Frame Origin

Setting the frame origin is the premise for saving the pattern's start point and setting frame protection at sudden power-off. So after the installation or maintenance of machine, it's necessary to set the frame origin.

1. Press " " key to enter the interface for frame selection and position.
2. Press  to enter frame parameter setting interface.



3. Select "Auto Find Origin Point" 

System will move the frame automatically and determine the origin according to the limit switch. So please ensure that the limit switch has been installed into the machine and activated.





8.3 Set Offset Point

The offset point can be set at any point other than the start point. When the machine starts embroidering after the settings, the frame will firstly move from the offset point to the start point and start normal embroidery. After embroidery, the frame will move back to the offset point. Moreover, the offset point is also the standard for frame to move out at appliqué embroidery. The function can only be used under the embroidery confirmation status and before embroidery.

1. In Embroidery Status, click  to have access to the frame selection and position interface.



2. Click the key for setting the offset point , clear the start point.
3. Move the frame to the offset point: Press the frame-moving key to move the frame to the offset point.
4. Click  to confirm the operation. System will save the position of the offset point.

8.4 Frame Origin Recovery

After power-off, if the frame is moved, this operation can be used to restore the frame position when power resumes. There are two operations you can do, operation 1:

1. In Embroidery Status, click  to have access to the frame selection and position interface.



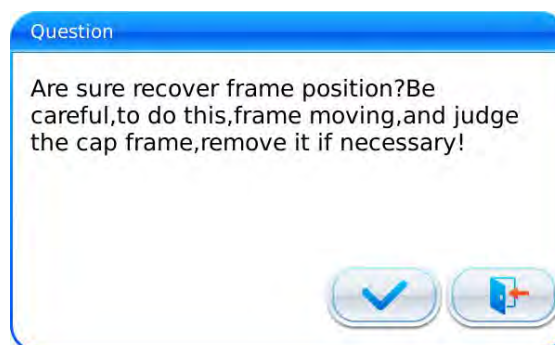

2. Click the key for setting the offset point , "Are sure recover frame position?" dialogue window will pop up automatically.



3. Click  to Frame Origin Recovery, click  to exit.

Operation 2:

1. Press  in the main interface and press  (for user) to enter parameter setting





interface.

- Setting parameters "Whether to boot prompt recover frame position": Click "Yes", and this setting dialog box will automatically pop up when starting up ; Click "No", this operation dialog box will not be prompted when starting up.

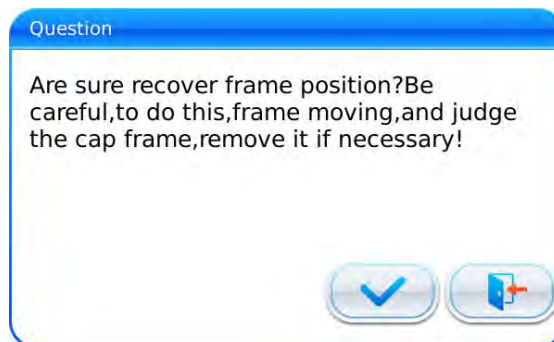

- When the machine is powered on, "Are sure recover frame position?" dialogue window will pop up automatically.



- Click  to Frame Origin Recovery, click  to exit.

8.5 Positioning Idling

This operation can only be undertaken under embroidery confirmation status .

This function can move the frame to certain position without embroidering according to





user's need. User can select color-changing code or stop code as reference to idle forward (or backward).



8.5.1. Low Speed Idling Forward

1. In the main interface , press 
2.
 - (1) Press  to idle forward continuously.
 - (2) Press  to idle forward by one stitch.

8.5.2. Low Speed Idling Backward

1. In the main interface , press 
2.
 - (1) Press  to idle backward continuously.
 - (2) Press  to idle backward by one stitch.

8.5.3. High Speed Idling Forward



1. In the main interface , press 



2. Press  to idle forward at high speed





Note: the operation method of high speed idling backward is the same with here.



8.5.4. Go to Next Color

1. In the main interface , press 
2. Press  to idle to the next color-changing code

Note: the operation method of “go to previous color” is the same with here.

8.5.5. Forward Idling

1. In the main interface , press 
2. Input the stitch number.  100 

System will have access to the interface for inputting the forward stitch number. Customers need to click  to confirm the operation, or click  to cancel the operation.





3. System returns to the main interface, press  to have the frame float the pointed position.

8.5.6. Backward Idling

The operations are similar to “Forward Idling”. The only difference lies in is to “press ”.

Chapter 9 Assistant Operation Function

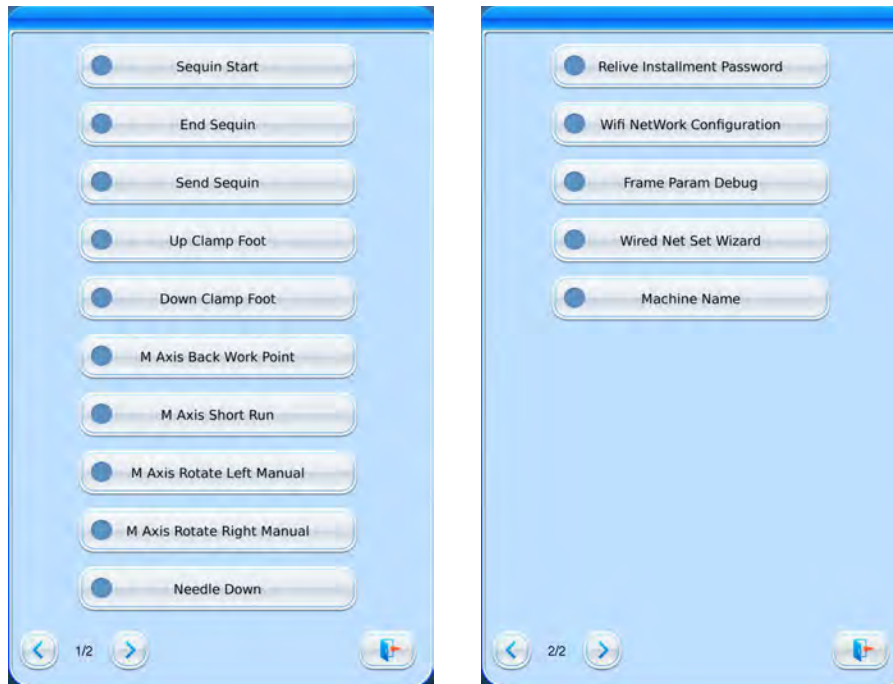

These functions are carried out by clicking the keys on the Assistant Operation screen.

Click  →  to enter Emb helper functions screen.



9.1 Needle Down

This function is designed for whole cloth embroidery (quilt embroidery). After part of the embroidery is finished, the needle will stop and prick into the embroidery cloth to fix it. After user releases the cloth, the machine will move the frame to the designated position. When the cloth is fixed on the frame again, next operation for the embroidery can be performed. This function can only be used under the embroidery confirmation status.

1. Click  →  to have access to the Assistant Operation interface.
2. Click the key of “Needle Down”. Confirm needle down action

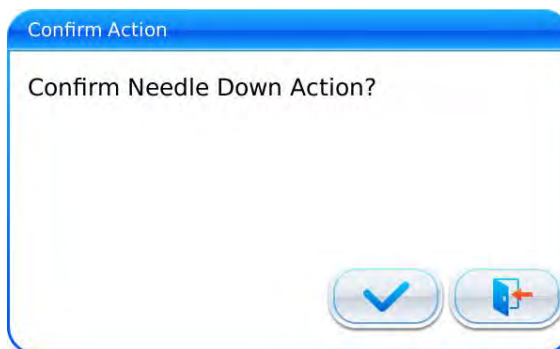

You can click  to confirm operation, and then the needle will prick into the cloth.

Click  to cancel.

3. Release cloth, move frame, and then press Enter

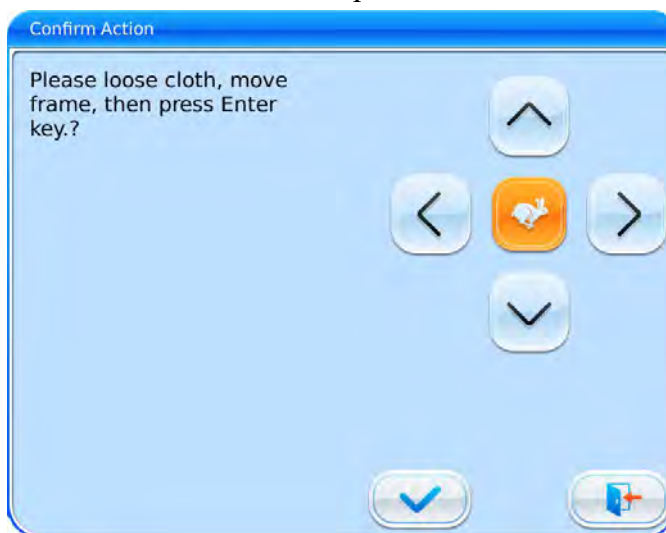

Users need to release the cloth and move frame to designated point, then click  to confirm.

4. After user confirms the frame-moving, system will returns to the main interface.



Customers need to fix the cloth, and then press the Start to continue embroidering.

9.2 Wifi NetWord Configuration

This function can be used to patterns' transfer by wireless, such as doodle art embroidery, Chinese embroidery, picture embroidery.

There are two ways to set up the WIFI Network Configuration

First method:

1. Press  → , access to the Assistant Operation interface
2. Press “wifi Configuration”, access to wifi network configuration interface





3. Press “wireless network” and set wifi network function, press , and refresh.



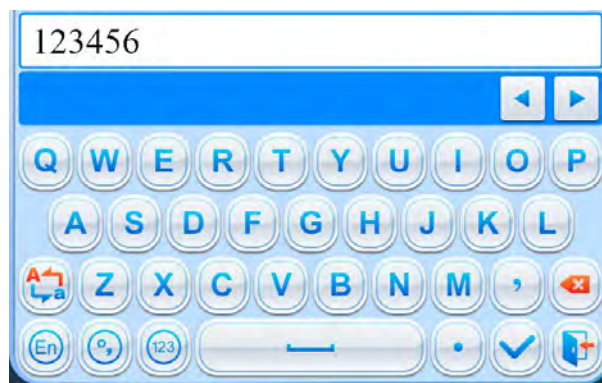

4. Chose the network, press “connected”, access to the wireless password interface





- enter the password, press , return the wifi network configuration interface, if press , the operation will be canceled
- After wifi network configuration finished, the interface will be like:





- Wireless connection status: from  to .

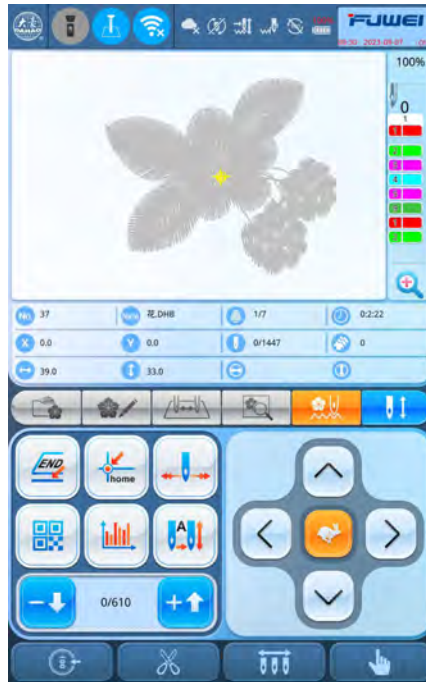

Second method:

- In any interface



2. Press , access to wifi network configuration interface



3. Follow the same steps as the first method



Chapter 10 Other Functions

These functions can be used during the usage, including machine maintenance, information inquiry and system settings.

Press  to enter the interface for other function, where a list of function keys will be displayed for user to operate by pressing.



The words on the keys can help user understand the functions.

10.1 Statistics

1. Press  to enter the interface of statistics.



In the above interface, the statistic information is displayed in a chart. If user need check details of each pattern, press to enter the corresponding interface.



Press to return to the interface of statistics. Press to delete statistic information and press to return.



10.2 Machine Debugging

 *This operation is only for repairman, ordinary users are banned to undertake these operations. Because these operations involve some mechanical work, please pay attention to the personal safety and equipment security during the operation.*

Debugging function is to mainly used for testing, maintenance and fault inspection of the machine, which include the following function (debugging items will be different for the different models):



Debugging Interface 1	Debugging Interface 2
Main Shaft Test	Main Shaft Speed And Encoder Test
	Main Shaft Angle
Trimming/Mac. Head Debug	Trimming solenoid/Motor
	Hold solenoid/Motor
	Hook Solenoid/Motor
	Hook Solenoid/Motor Continuous Test
	Head Solenoid/Motor
	Upper Thread Clamp Test
Trimming/Mac. Head Debug	Trimming Motor Origin
Breakage Detection	Change needle position, needle bar color and adjust main shaft manually
Sequin Test	Sequin Presser Up/Down
	Sequin Motor A1/B1/C1/D1 Feed
	Sequin Device Gap Valve Open/Closed
Simple Rope Embroidery Test	
Driver Parameter Test	Frame Param test
	Main shaft parameter test
	Driver param Import
	Driver param Export
	Frame Param Select
Sensor Status Test	Test pull bar switch, frame limit, knife

Debugging Interface 1	Debugging Interface 2
	origin, knife maximum point, thread-hooking origin, and needle position display, etc.
Peripheral board Management	Peripheral board upgrade
	All Peripheral Board Write Address
	All Peripheral Board Address Check
Boot Loader Upgrade	
Param Export/Import	Import machine parameters
	Export machine parameters
Param Init	
Update Logo	
Touch Screen Calibration	
Function Config	Sequin, Simple Cording, Glass beads
Photo Emb. Authorized	
Special Broidery Authorized	
Machine Debug Authority Passwd Change	



10.2.1. Touch Screen Correction

After using for a period, the touch screen may probably have the problem of the inaccurate operation. This problem can be resolved by touch screen correction. During the correction, please touch the very center of the cross displayed on the screen, or it may affect the future operation. In order to avoid the trouble caused by the inaccurate correction, this operation is only for the person with authorization.

Operation 1:

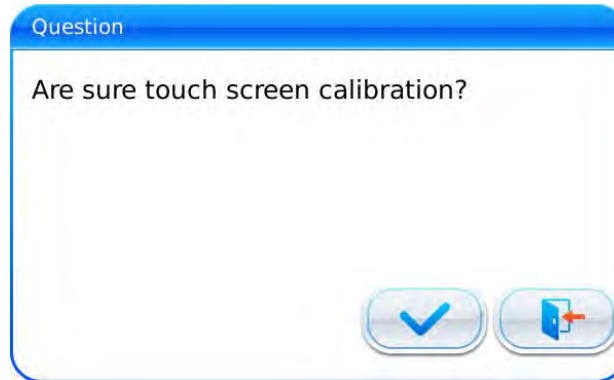
1. Press  to enter the interface for other functions.
2. Press  to enter debugging interface, press “touch screen calibration”.



3. Press  to enter the correction interface. Press  to abandon the touch screen calibration and return to the interface for other functions.

4. Press the center of the crosses one by one.



During the process of correction, a lot of crosses will appear on the screen. User should press the center of them. System receives the data of those points and saves them as standard data for correction.

5. System will make correction according to the coordinates of points pressed by users.

System will make the correction and then return to the interface for other functions automatically.

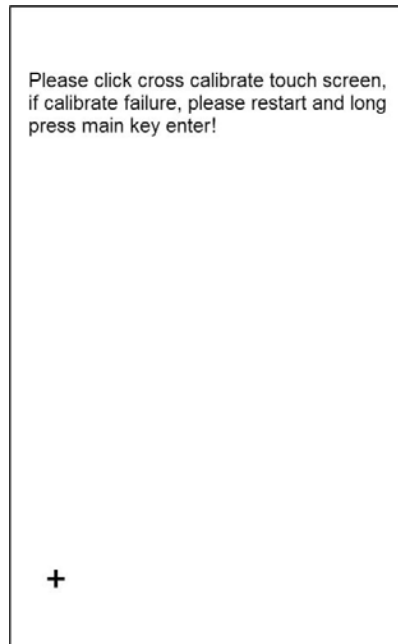

Operation 2:

1. Press  when the initialization interface display until enter to the touch screen correction interface
2. Press the center of the crosses one by one according to the prompt, and abandon the touch screen calibration, then restart system, should be normal when touch any position of the screen.



10.2.2. Function Configuration

Is should display the related functions and parameters in machine parameter, assistant operation and debugging interface. For example, Sequin function configuration, in function configuration, chose 'sequin', and check machine parameter, assistant operation and debugging interface, the related sequin functions and parameters will be displayed.

1. Press  to enter the interface for other functions.
2. Press  to enter debugging interface, press "Function Config".

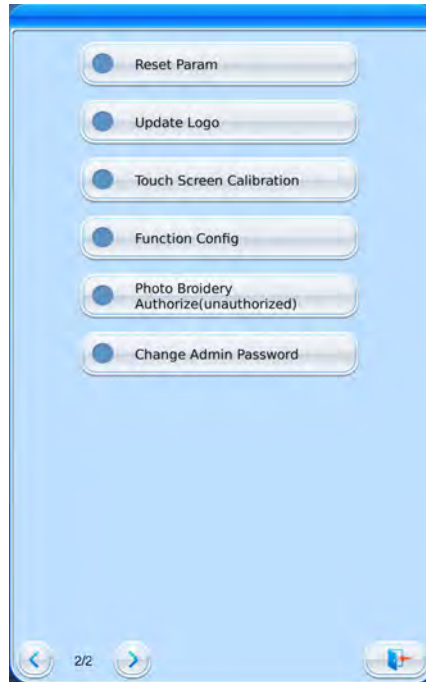

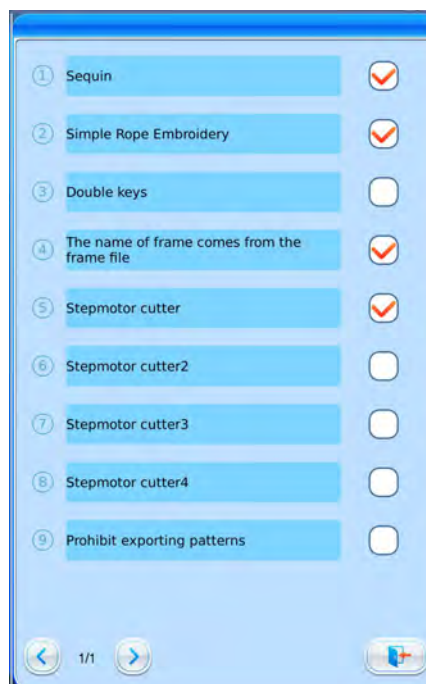

3. Access to function configuration interface, press 'sequin'



10.3 Language

System supports Chinese, English, Turkish, Spanish, and so on.

1. Press  to enter the interface for other functions.
2. Press  to enter language interface.



Select the language you want and system will enter the main interface in the selected language.

10.4 Date Set

In date set interface, user can check and modify the date and time of the system.

10.5 Information

Operation Procedures:

1. Press  to enter the interface for other functions.

2. Press 



This function will help user check machine software information. Press  to quit.

Note: You can view the peripheral board pc2220, and the software must be above 3.0.



Chapter 11 About JF Sequin Embroidery

11.1 Brief of Sequin Embroidery

Sequin embroidery is formed by many sequins and the specific stitch form. Because the sequins are made of the hard and shining material with smooth surface, the sequin embroidery, formed by the sequins with different colors, shapes and sizes, features the unique shining effect. The design with sequin code has its own pattern format.

JF Type multi-sequin embroidery is divided into two types on the designs: one is normal multi-sequin design, made by the traditional pattern-making method; the other is special multi-sequin design, made by the normal design software with the special pattern-making rules.

For normal multi-sequin design, user should set sequin mode when modifying the color-changing order. But the special multi-sequin design can be directly embroidered only after modification of color-changing order, which means user doesn't need to set the sequin mode.

Meanwhile, the machine can automatically change normal design to special design during the process of design import. The new special design saves the entire sequins in the original normal design as sequin A. If you want further modification, you can use "Sequin Edition" to modify. The multi-sequin design after the modification is the special multi-sequin design.

I . Application Range

This system is applicable to the sequin embroidery control system that combines normal embroidery mechanism, zigzag embroidery device and sequin-feeding mechanism.

II .Features

1. Support two sequin-feeding method: Wheel and Lever;

Wheel: The core part for feeding the sequins within this device is the mechanism like a wheel, which transports the sequins to the proper position by rotating in the single direction.

Lever: The core part for feeding the sequins within this device is a lever mechanism, which will send the sequins to their positions with its alternating motion.

2. Separate action of sequin-mending and sequin-feeding device;
3. Manual separate or collective feeding at single time;
4. Separate display of the working statuses of sequin device;



5. Sequin-feeding method and the feeding angle can be changed via the operation panel.

III. Specifications

1. Size of Sequin available: Diameters at 3mm, 4mm, 5mm, 6.75mm and 9mm;
2. Max speed at 1000rpm.





11.2 Embroidery Procedure of Sequin

At sequin embroidery, user needs to follow the procedure at below:

1. Input design with sequin code, refer to 11.3
2. If necessary, please transform and edit the design, please refer to 11.4);
3. Set the sequin parameter according to the setting instructions in 11.5.
4. Check and adjust the sequin-feeding device (Refer to 11.7), so as to make sure the sequin-feeding device works normally;
5. Set color-changing order
6. Return to main interface and confirm the embroidery;
7. Start embroidery.

Attention: during the embroidery, don't dial the manual switch for moving the valve, or it will cause the damage of the sequin-feeding device.

11.3 Input Sequin Design

Press  in the design management to enter disk selection interface to open the disk needed. After selecting design for input, user needs press  to “Whether support multiple gold or not”, choosing “” is to save it as the special sequin design no matter what is was. For the normal sequin designs, the changed sequin designs will save all the multi-sequin within the original design as “A” type sequin. If you choose “”, normal sequin designs remain as they are, while special multi-sequin designs will be saved as special multi-sequin design.

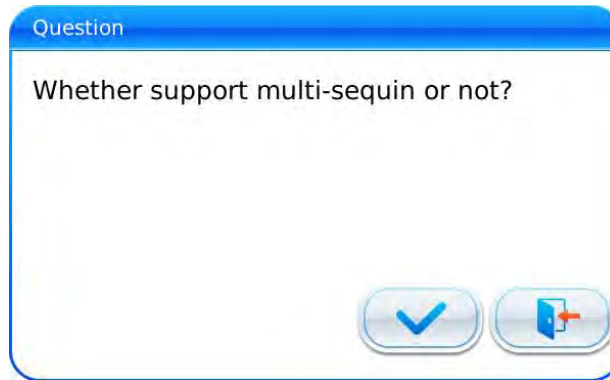

Enter to have access to the design input interface as shown in below:

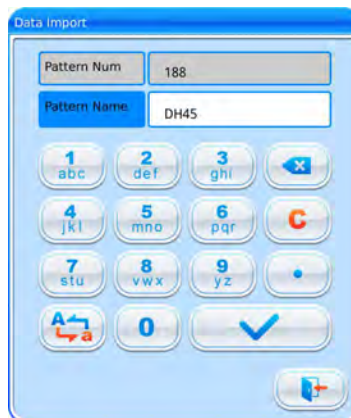

Setting procedures: User should input number and name of pattern.

11.4 Edit Sequin Design





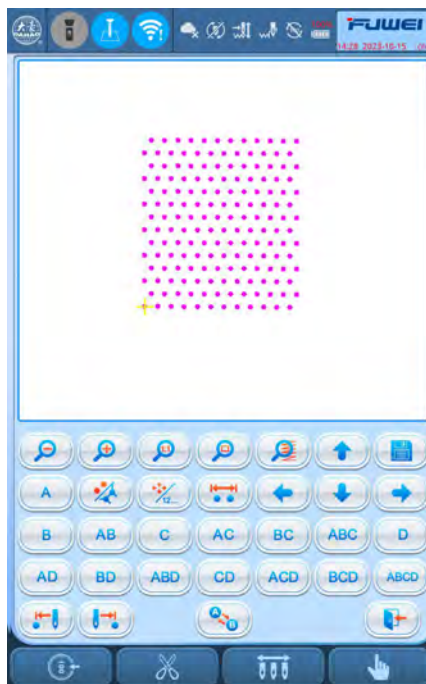

This function is to edit sequin design within the system. After edition, all the designs will be saved as special multi-sequin design. User doesn't need set the sequin mode at modifying the color-changing order

1. In the "Pattern Management" interface, select sequin design for edition. Click



"", "Edit Gold Picec Pattern" in order to enter the "Edit Design" interface.



2.  Display design in the center;  Display design 4.5 times as original one;  Zoom in sequin design;  Zoom out sequin design;  Display in original size
3. Click  to show all stitch forms of the design, as shown below:

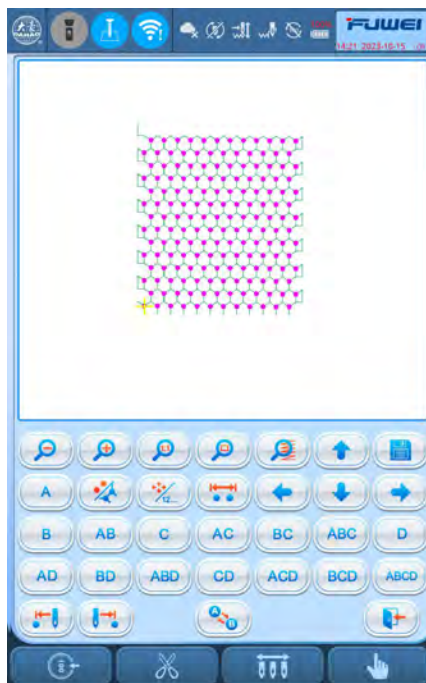

4. Click  to shift the current stitch mode between “navigating by position” and “navigating by stitch number”. “navigating by position”: when you press direction keys, the next stitch code in that direction will be selected, regardless at its stitch

number. “navigating by stitch number”: when you press direction keys “leftward” or “upward”, the last sequin stitch code (smaller than the current number) will be selected; when you press “rightward” or “downward”, the next sequin stitch code (bigger than the current number) will be selected.

5. Click  to enter into “Sequin Range Edit”.

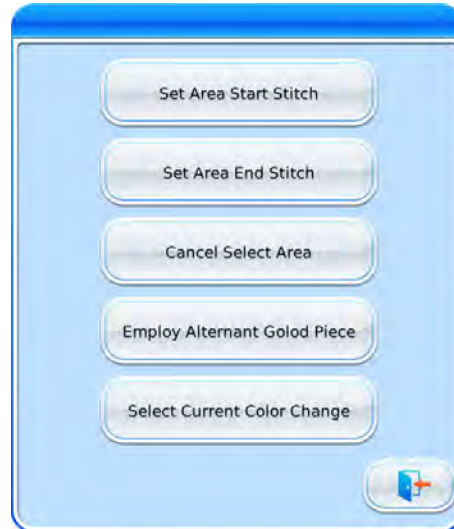

- (1) Move the cursor to a stitch position, then click “Set Range Start Stitch” to set the current stitch as the start stitch of this area. Move the cursor to a different stitch position, then click “Set Range End Stitch”. The area for setting is from the start stitch to end stitch.
- (2) If you want to cancel the area, click “Cancel Range”.



6. Sequin Mode Selection

There are 15 kinds of sequin modes for customers to select, including A, B, AB, C, AC, BC, ABC, D, AD, BD, ABD, CD, ACD, BCD and ABCD.

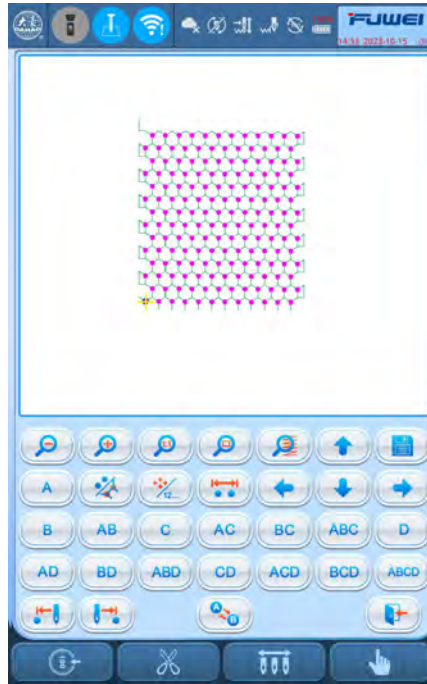
Names of these 4 sequins: A, B, C and D. If these 4 sequins are delivered at same time, then A will be on the top, then B, C and D.





7. Edition of Alternating Sequin

If you want to use the alternating sequin, you should define a range for using them at first. In “”, use “Set Range Start Stitch” and “Set Range End Stitch” or “Select Current Color Range” to set sequin range. After that, use “Edit Alternating Sequin” in “” to set the alternating sequin used.



Setting method:

- a) Click  or  to select sequin mode and click  to confirm. Sequin names are A, B, C and D. If all these four sequins are included, A will be on the top, then B, C and D.

b) After that, press to confirm the sequin-feeding mode. Then the system will ask user to input the number of sequins fed. Click the number keys to input the number (Range: 0~9999). If a sequin group is only used for one stitch at the embroidery cycle, user will need to input “1” and then press .

c) Click or until you see “END” in the blank or the feeding number becomes “0”. Press to finish the setting.

For instance, if the current sequin mode is A2ABCD1CD1, the design will be like the one at below:

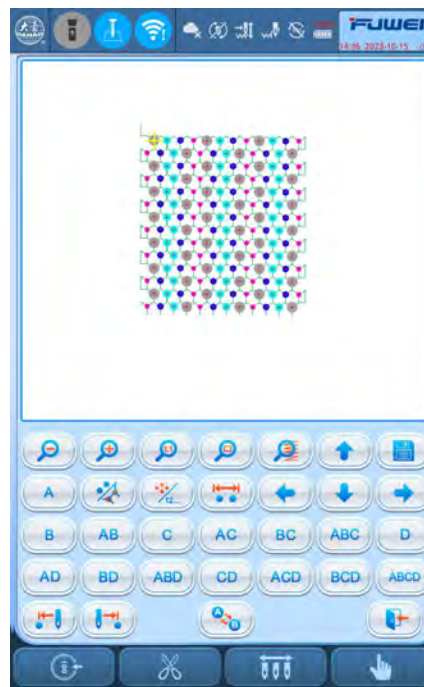

8. Save

When you finish the edition, click to save the design.

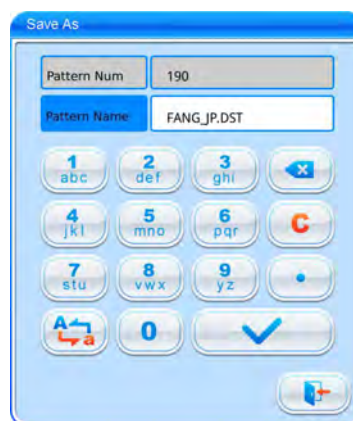



Input design number and name, then click to save the edited sequin design, or click to cancel the saving.



11.5 Setting of Multi-Sequin Embroidery Parameters

In this section, we will introduce how to adjust sequin device and the parameters used in multi-sequin embroidery.

Press  in the main interface, select "Expert Param"  to enter parameter management interface, then select Sequin Parameters to have access to the interface for setting the sequin parameters.

1. Limited Speed for Sequin R(L):

The parameter is to set the max speed during normal embroidery.

Note: the maximum speed of flat embroidery should be higher or equal to speed for sequin embroidery.

2. L/R Sequin Feeding Angle Adjustment

This parameter is to adjust the sequin-feeding angle.

3. Auto Start for Sequin

When the setting is "Yes", system will start embroidering sequin automatically.

When the setting is "No", machine needs manually start at sequin embroidery.

4. Time of Sequin Action

This is to set the time from sequin device going down to starting embroidery (0-15, the default value is 2). If the sequin-feeding device is controlled by valve, use the default value; if that device is controlled by motor, please set it at 4~5.

5. Sequin off after T.B.

When the setting is "Yes", sequin presser foot will be up automatically in case of thread-breakage.

When the setting is "No", the user needs to lift the presser foot manually at thread-breakage.

6. Sequin Ind. Up/Down

When the setting is "Yes", the sequin devices will move independently. When the setting is "No", they will move collectively

7. Lift Valve at Jump without Trim (Y/N)

8. Base of Shift Travel at L/R Motor

9. Multiple of Shift Travel at L/R Motor

10. Has Origin at Shifting L/R Motor

The parameter No.8, No.9 and No.10 are for the special sequin device that uses the motor



(Single Needle Double Sequin) to shift the travel between large sequins and small sequins. There are two kinds of device: one has the shift origin; the other has no shift origin.

11. Beam-breakage Detection Sen.

This parameter is used for the beam embroidery device. “0” is to turn off the sensitivity, the range of this parameter is 0~10. The smaller value means the higher sensitivity of the detection device.

12. Motor Number of L/R Sequin

The setting of this parameter should be based on actual device condition, if there is no sequin device, please set it at 0.

13. Set 2/3/4/5/6.75/9mm of L/R Sequin

This parameter group is to set the sequin delivery angle. If it is wheel type sequin-feeding device, please set it at single way; if it is lever type sequin-feeding device, please set it at double ways. The parameters of this type are set correctly when the machine is produced. This kind of parameters is closely related to “left/right sequin device A/B/C/D size and color”. For example, “A size&color of R sequin” is set to “4mm X color”, and then the angle value should be the one in “Set 4MM of R Sequin”.

14. A/B/C/D Size &Color of R/L Sequin

The setting of this parameter should depend on the mechanical structure. The corresponded order from A to D is front motor to back motor.

Note: “Motor Number of L/R Sequin” is closely related to the number of A/B/C/D in “A/B/C/D Size&Color of R/L Sequin”. For example, if “Motor Number of L/R Sequin” is set to 2, then only the “A/B size&color of R/L sequin” will be displayed.

15. Sequin Gap Num. of L/R Sequin

This is to set gap number. If there is no gap, then it should be set to 0.

16. L/R Sequin Valve Action Time

This parameter is for setting the response time at adjusting the valve action. The larger value means the longer response time. Please set it according to the actual condition of device. Default value of it is 2.



17. L/R Trimmer Action Angle Adj.

This parameter is used at the special sequin device that uses motor to cut the sequin for adjusting the start time of the sequin-cutting motor. The default value of it is 15. The smaller value means the earlier action of motor, the range of this value is 0~31.

11.6 Manual Operation of Sequin Embroidery

The manual operation part contains “Sequin Start”, “Sequin End” and “Sequin-feeding”.



- (1) Click  for selecting “sequin start” to let all the presser feet get down;
- (2) Click  for selecting “sequin end” to lift all the presser feet;
- (3) Click  for selecting “send sequin”; the activated machine heads will send a sequin at each clicking (with presser foot at down position).

11.7 Debugging Multi-Sequin Embroidery

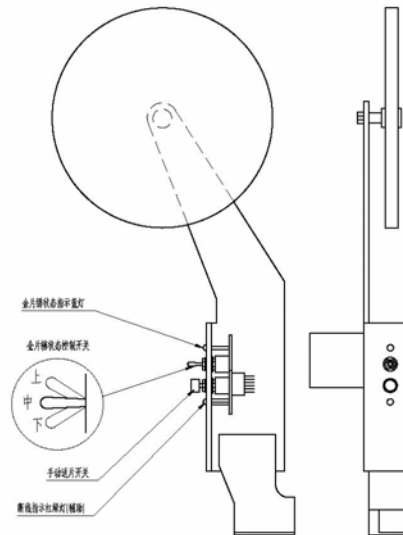

Location of Sequin Switch Board

1. Operation of Sequin Switch

(1) Manual Operation for Front Motor Sending A Sequin

Put the sequin switch to the down position, dial the thread-breakage detection switch to turn on the green indicator and press manual sequin-feeding button.

(2) Manual Operation for Middle Motor Sending B Sequin



Put the sequin switch to the down position, dial the thread-breakage detection switch to turn on the red indicator and press manual sequin-feeding button.

(3) Manual Operation for Rear Motor Sending C Sequin

Put the sequin switch to the down position, dial the thread-breakage detection switch to turn off the head indicator (dial it to down position too) and press manual sequin-feeding button.

Note: In order to debug the multi-sequin function, user needs to install an external head switch on the single head machine.

2. Debugging Menu of Sequin

Press  and then press “machine debugging”  . Then press “Sequin

Device Operations” to show the following image::



Then you can select related operation for debugging.

11.8 Sequin Mending

After the thread breaks or the red thread-breakage detection indicator is turned on manually, press the stop key to retreat and have the system enter the mending status. At mending status, the sequin devices will go up and the machine will return and stop at the mending point. Then user can press the Start key to perform the mending embroidery for sequin. The mending embroidery will turn to the normal embroidery at the thread-breakage point. Among the machine parameters, the “Patch Count” is unavailable in the in sequin mending operation.



Chapter 12 Operation of Zigzag Embroidery

12.1 Functions

1. Zigzag Embroidery (ZIG Embroidery): this function is to make the thread form the design with certain stitch forms, which have been saved in the computer in advance, the Z4 and Z5. The figures of these two kind of ZIG embroidery are shown at below:



Z4 Embroidery



Z5 Embroidery

2. User can set the max speed for flat embroidery and the top speed for zigzag embroidery respectively.
3. Auto saving of the stop point of the M axis: M axis will return to the stop point when the power resumes.
4. Thread-trimming for Zigzag Function (Trim bottom thread Only)
5. Before manual frame-moving, the zigzag device can lift the presser automatically, while it can also lower the presser before the embroidery.

12.2 Key Technical Indexes

- 1、 Speed of Zigzag: 300~850rpm, unit: 10rpm.
- 2、 M Axis Manual/ Auto Rotation Step: 18° /Step.

12.3 Procedure of Zigzag Embroidery

- (1) Input zigzag embroidery design, then select, adjust and edit the design according to needs;
- (2) Change parameter, select color-changing order and decide embroidery mode;
- (3) Check zigzag embroidery position, and make sure it works normally;
- (4) Start Embroidery

12.4 Related Parameter and Setting Mode

Press  in the main interface , select "Expert Param" , then user can set



the parameters relating to the zigzag embroidery.

1. Right Zigzag Device: Y (N) —— Y means the first needle is the zigzag embroidery position.
2. Left Zigzag Device: Y (N) —— Y means the last needle is the zigzag embroidery position.
3. Zigzag Device Move Time: 2 (Default Value) —— User should set this value according to the actual action time of zigzag device.
4. Top Speed of Zigzag: 600 (Default Value). The top speed can be set to 850rpm, but user needs set it on basis of the actual condition of machine.
5. Swing Range of Zigzag: 100 (Default Value). This value is the rotating angle of the wheel. At the circumstance of thread-floating, user can decrease this value to relax the influence as an assistant method. Generally, this value should be no less than 80.
6. Frame Swing of Z5 Embroidery: by adjusting the frame, user can change the embroidery range (The senior users are recommended to use this parameter).
7. Zigzag Thread-loosing Adjustment Value: this is to adjust the thread-sending speed of all the thread-loosing motors. The recommended value is 9.
8. Zigzag Right Device Origin: this is for the angle between the threading point and the direction of the mechanical origin of zigzag device at first needle position. Angle = Parameter value *0.9. For an example, the parameter value is 80; the angle will be $80*0.9=72^{\circ}$.
9. Zigzag Left Device Origin: this is for the angle between the threading point and the direction of the mechanical origin of zigzag device at last needle position. Angle = Parameter value *0.9. For an example, the parameter value is 80; the angle will be $80*0.9=72^{\circ}$.
10. Greateff mode: 5(1~5)
11. Work mode: 2(1~5)
12. Actuation time adj: 50(1~20)
13. Looped time: 50(30~100)
14. Whether cut line when jump: Yes/No.



15. Thread-loosing Motor for Zigzag Embroidery: Yes/No. if the device is double motor taping device, user needs to set it at “Y”, or user should set it as “N”.
16. Zigzag Device Movement Detection: Test whether the device moves to the proper position. User needs set this parameter according to the actual condition of the device.
17. Test Thread-sending Motor of Zigzag Device (Y/N): The default value is “Y”. “Y”: the thread-sending motor will not rotate until the position of hall component is checked. “N”: The thread-sending motor will run as long as the system is at embroidery status, regardless the position of the hall component. It can only be used at the “107-P03-1.0” and higher version (for PC107 Board) or the “107B-JY-1.0 & 107B-DB-1.0” and higher version (for PC107B Board).

12.5 Relative Operations of Zigzag Embroidery

12.5.1. Shift between Flat Embroidery Position and Zigzag Embroidery Position

(1) Manual Shift

In the main interface, press the key  to enter into color-changing interface.

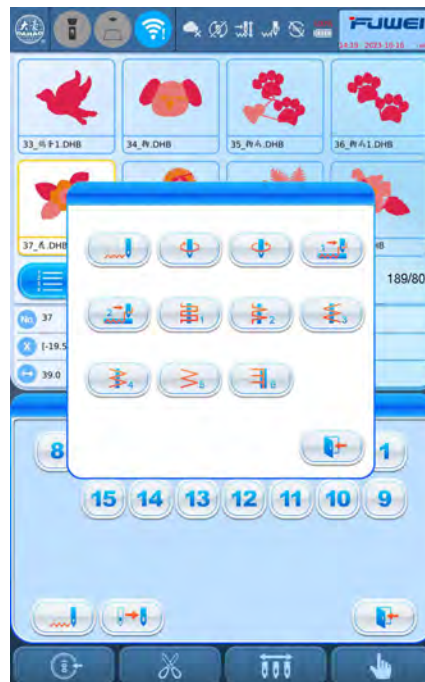

The  indicates the embroidery mode of the current zigzag embroidery. Click that

key to change the embroidery mode. If user has nothing to change, please press  to exit.

Definition of icons:



Normal Embroidery;



Z4 Embroidery: The rod swings at each stitch.





Z5 Embroidery: The feature of it is same to Z4. It is suitable for the thick thread.

(Refer to the parameter: Swinging scope of frame in Zigzag sewing)

(2)Automatic Shift

Before embroidering, automatic shift can be achieved through setting the color-changing position.

In the main interface, press “” to enter into color changing interface, and then press the key  (zigzag head) to change zigzag embroidery mode:



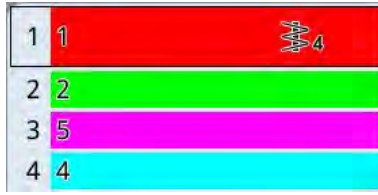

Press the corresponding icon to select the very zigzag embroidery mode, if you don't want to change, and then press  to exit. After confirmation of the embroidery mode and the setting of color-changing order, the system will display as below:





12.5.2. M Axis Operation of Zigzag Embroidery

The operations about M axis contain “M axis to be ready”, “M axis to cycle” and “M axis to turn”, which are all in the Assistant Functions. In the main interface, you can click  to enter into the “Assistant Operation” interface. Turn the page, then you can see the parameters “M axis to be ready”, “M axis to cycle”, “M axis rotate left manual” and “M axis rotate right manual” displayed in order..

(1) Return M Axis to Working Point

Press the key “M axis to be ready” and click  on the dialogue window to let the M axis back to the working point, click  to exit.

(2) Return the M-axis to the Origin Point (Step Moving)

Press the key “M axis to cycle” and click  on the dialogue window to let the M axis rotate to the “Zero point”, click  to exit the operation.

(3) M axis rotate left manual

Press the key "M axis rotate left manual" to let the M axis rotate to the left. It will rotate 18° left once you click the button. After 20 times click, it will return to its origin;



(4) M axis rotate right manual

Press the key "M axis rotate left manual" to let the M axis rotate to the right. It will rotate 18° right once you click the button as well. After 20 times click, it will return to its origin.



Chapter 13 Taping Embroidery



13.1 Function Introductions

1. Taping function: Tape can be used as embroidery material. It includes taping 1  and taping 2  (blind embroidery)
2. The presser of special embroidery can go up and down automatically or manually. (This function is only for the machines installed with relevant apparatus)
3. The highest speeds of flat embroidery head and special embroidery head can be set respectively.
4. Auto-saving of the M axis stop point at power-off: The machine can continue the work from the stop point when the power recovers.
5. The trimming function of the special embroidery head (no trim\trim the bottom thread\trim both the upper and bottom threads)
6. The presser of special embroidery can go up automatically before manual frame-moving and go down before embroidery.

13.2 Main Technical Specification

1. Speed of special Embroidery: 300—850rpm, adjusting step at 10r/m.
2. Manual rotating angle of M-axis: 18° /step.

13.3 Parameters and setting

Press  in the main interface , select "Expert Param"  , then user can set the parameters relating to the zigzag embroidery.

The remarks of these parameters are at below:

1. D28 Special Head Interval:..Range: 10~1000
2. D30 Clamp Foot Displace: 0~90

This parameter is to adjust the lifting height of clamp foot at each stitch.

3. D40 Adj Clamp Foot Limit: 0~250

This parameter is the Max height of the clamp foot.



4. D31 Rod Pos. of ZIG: Left/ Right

The “ROD POS. OF ZIG” determines the position of swing rod when M axis is in origin. This parameter must be set in accordance with actual mechanical position.

5. C38 Swing Value of ZIG (0~10)

The parameter is for Z5 embroidery and applies to thick cords. For thick cord embroidery, at Z5 embroidery, the system moves the frame to compensate the swinging scope of the lever.

6. D42 Rotary Gap of M Axis: 0~10

The M axis of special embroidery head has mechanical gap, so it will generate the mechanical difference after M axis changes rotating direction repeatedly. At embroidering the flat tapes, if the shape of tape is curve and the M axis has no angle compensation, the needle will fall at the edge of the tape instead of the right position at each turning.

Adjusting this parameter value is to ensure that the needle falls in the center of tape. During machine debugging, parameter value should be “0” when needle falls in the center of tape. If not, please repeat the adjustment to realize the best effect.

Generally, this parameter should be managed by professional experts before leaving factory.

7. D44 M Axis Work OFF Angle: 0, 90

In normal and sequin embroidery, if this parameter is set at 0, the M axis will stop at the horizontal position; if it is set at 90, the M axis will stop at the vertical position. When the distance between the normal embroidery head and special embroidery head is small, this parameter must be set as 90° to avoid crashing.

8. D39 Z Shift Control Angle: 0~180

When the rotating angle is larger than the set value, the Z axis will wing faster.

9. D41 Adj Zig Rod Angle: 1~3

It is the starting angle of the rod, which indicates the relative position of the needle bar and thread. It is used for adjusting the embroidery quality. “1” means the swing starts at an early angle; “2” means the swing postpones certain angle; “3” indicates the swing postpones certain angle again and starts.

10. C36 Ratio of Coil Emb. (The ratio of coiling) : “1~4 Sti/L”



The parameter can change the coiling density; e.g. the set value 2 means one coiling every two stitches.



13.4 Relative Operations of Special Embroidery

13.4.1. Shift between Flat Stitch Head and Special Head

(1) Manual Shift

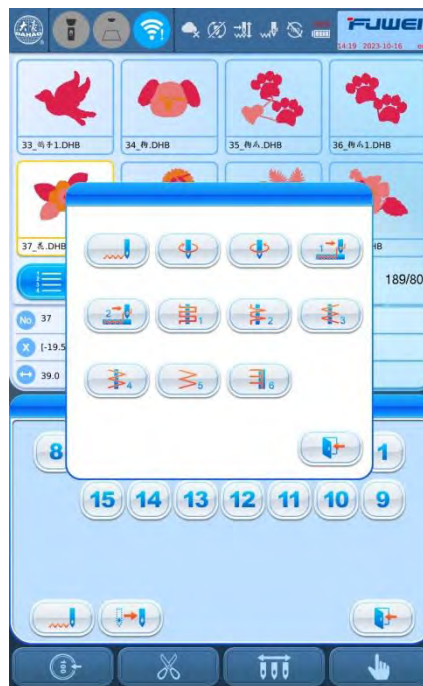
In the main interface, press the key  to enter into color-changing interface.



The  indicates the embroidery mode of the current zigzag embroidery. Click that key to change the embroidery mode. If user has nothing to change, please press  to exit.

Definition of icons:



 normal (lock-stitch);  right coiling;  left coiling;

 taping 1;  taping 2;

(2) Automatic Shift

Before embroidering, automatic shift can be achieved through setting the color-changing position.



In the main interface, press “” to enter into color changing interface, and then press the key  (zigzag head) to change zigzag embroidery mode:



Press the corresponding icon to select the very zigzag embroidery mode, if you don't want to change, and then press  to exit. After confirmation of the embroidery mode and the setting of color-changing order, the system will display as below:



13.4.2. M Axis Operation of Special Embroidery

The operations about M axis contain “M axis to be ready”, “M axis to cycle” and “M axis to turn”, which are all in the Assistant Functions. In the main interface, you can click  to enter into the “Assistant Operation” interface. Turn the page, then you can see the parameters “M axis to be ready”, “M axis to cycle”, “M axis rotate left manual” and “M axis rotate right manual” displayed in order..



(1) Return M Axis to Working Point

Press the key “M axis to be ready” and click  on the dialogue window to let the M



axis back to the working point, click  to exit.

(2) Return the M-axis to the Origin Point (Step Moving)

Press the key “M axis to cycle” and click  on the dialogue window to let the M axis rotate to the “Zero point”, click  to exit the operation.



(3) M axis rotate left manual



Press the key "M axis rotate left manual" to let the M axis rotate to the left. It will rotate 18° left once you click the button. After 20 times click, it will return to its origin;

(4) M axis rotate right manual

Press the key "M axis rotate left manual" to let the M axis rotate to the right. It will rotate 18° right once you click the button as well. After 20 times click, it will return to its origin.

13.4.3. Operations of Clamp Foot

In the main screen, click  to enter into the “Assistant Embroidery Operation” screen, select to “Nipple up” ,then press “”to lift the clamp foot, select “”to exit.

In the main screen, click  to enter into the “Assistant Embroidery Operation” screen, select to “Nipple down” ,then press “”to lift the clamp foot, select “”to exit.

13.5 Debugging Special Embroidery

Debugging special embroidery mainly includes Zigzag swing to its origin and test of clamp foot action. In the main screen, click  to “Machine Test” and then click “Taping” to have access to the screen of machine test.

1. Zigzag rod to 100

Move cursor to “Sway Zig Rod to 100”. According to the hint in dialogue window, user can pull bar to let all the swing rods act once. Click “”to exit.



Users can adjust swing range by using this function.

2. Clamp Foot Up/ down

Move cursor to “Test lift clamp foot”. According to the hint in dialogue window, user can pull bar to let all the clamp feet go up/down. Pull the bar again to let them down/up again.

Click “” to exit.

13.6 Steps on Special Embroidery

1. Input design, carry out design selection, changing and editing according to requirement.
2. Modify the relating parameters, select color-changing order and choose the special embroidery mode.
3. Check special heads and make sure they are in perfect condition.
4. Pull bar to start embroidering.

13.7 Mechanical Category and Driving Mode Selection for Special Embroidery Machines

Taping machines have three types of the motion parts in the sense of mechanics. We define them as M axis, E axis and clamp foot axis. M axis rotates a certain degrees at every stitch to trace the stitch, which ensures cords or tapes always in front of needle movement. E axis swings once at every one or two stitch to make the Zigzag embroidery. Clamp foot axis is used for lifting and lowering the clamp foot.

1. M axis

The mechanism of M axis can be divided to two types. One is with clutch device, whose action is controlled by electric valve or by hand. Its advantage is that only the M axis of the patching embroidery is moving and non-patching embroidery heads stay still at mending. This will enhance the quality and efficiency of mending. The other type is without clutch device. Both of the two types are driven by servomotor and the origins of their M axis are positioned by proximity switch.

2. E axis

According to the difference in motor and the equipment of proximity switch for



positioning the origin, E axis devices can be divided to the following types:

- 1) Driven by stepping motor separately, without proximity switch for positioning origin
 - 2) Driven by stepping motor collectively, with proximity switch for positioning origin
 - 3) Driven by stepping motor collectively, without proximity switch for positioning
 - 4) Driven by servomotor, with proximity switch for positioning origin
3. Clamp foot axis

The working progress of the special clamp foot is shown at below: (The clamp foot working height is the distance of the foot's movement at every stitch. The clamp foot rising height is the foot's moving distance from the bottom to the upper point at non-embroidery mode. And it's also called the clamp foot limited height.)

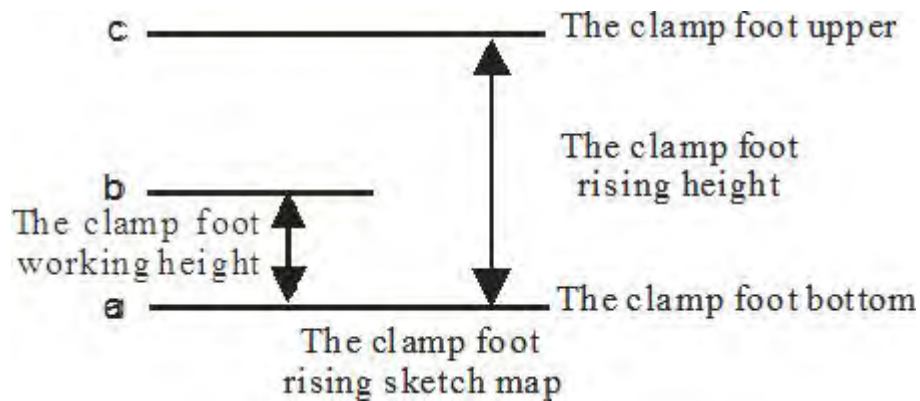





Chapter 14 Online Update of Main Software

Update Procedure:

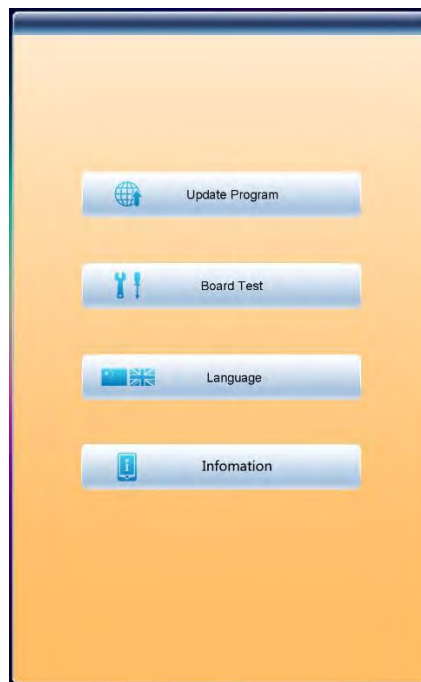
1. Hold pressing  and power on.
2. The screen will display the following interface, where user should select “update program”



3. Select the update method  (via U disk)

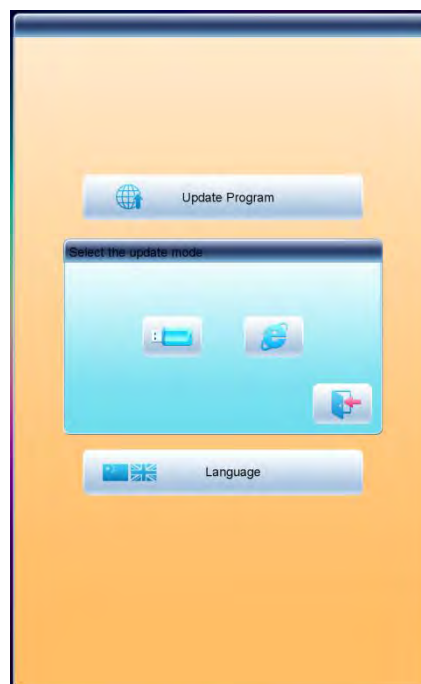



4. System will display the window to “Select U Disk”, and select the target U disk.

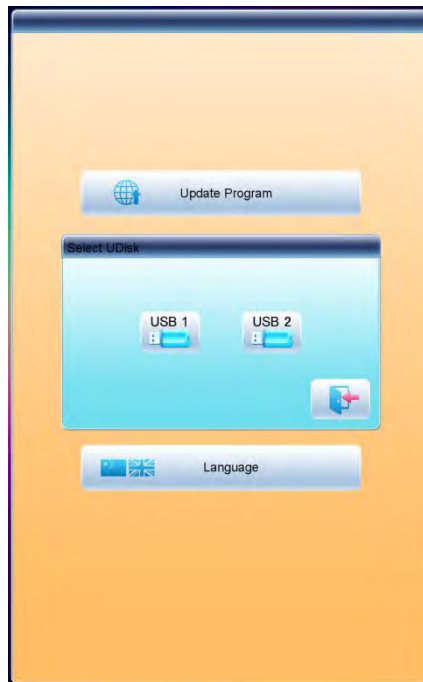

5. After entering the interface of the U disk, select the program to be updated.

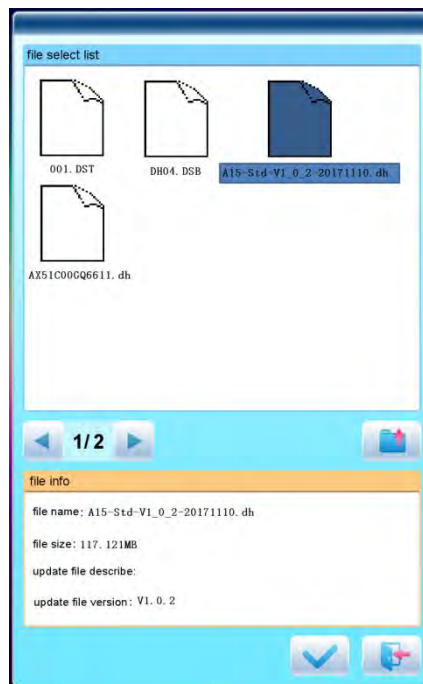



6. Press  to update.

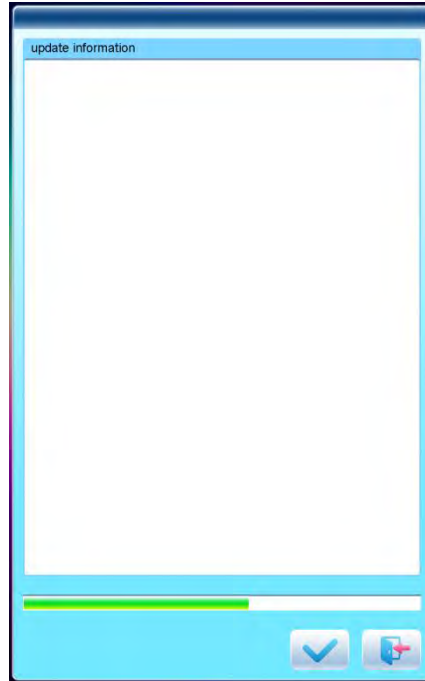

7. When finishing update, system will automatically display a hint “update completed, if no others, please restart”, and then please restart.



Chapter 15 Update of Software in Peripheral Board

Update Procedure:

1. Press  to enter the interface for other functions.



2. Press  to enter the interface of statistics.





3. Select “peripheral board management” to enter the management interface, where user should select “peripheral board update”.

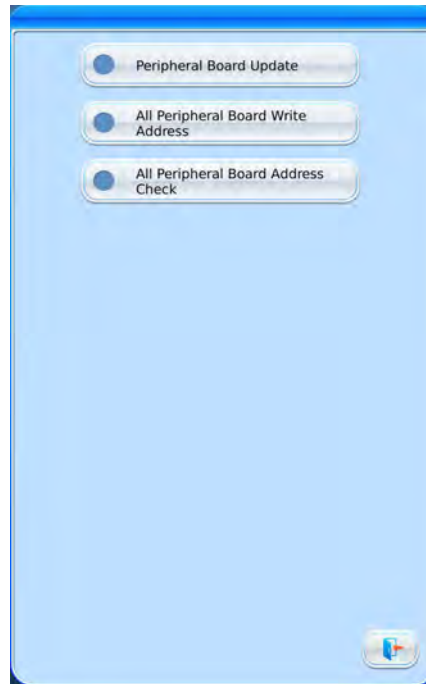

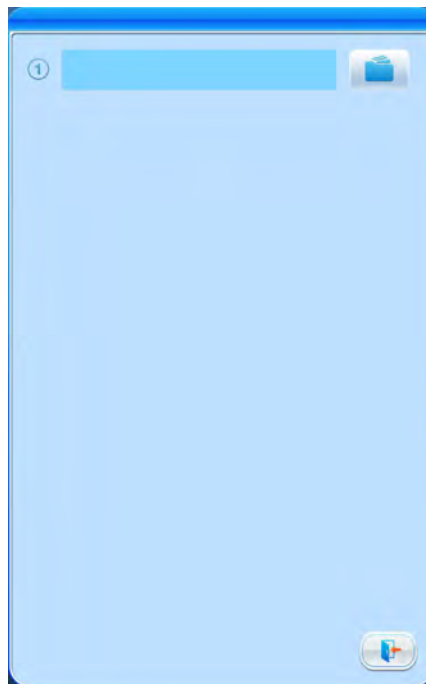

4. Press 



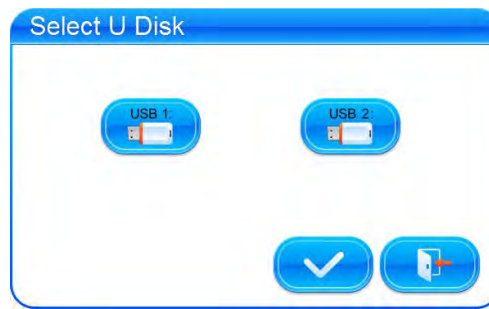

5. Select the U disk



6. Select the program to be updated and press 

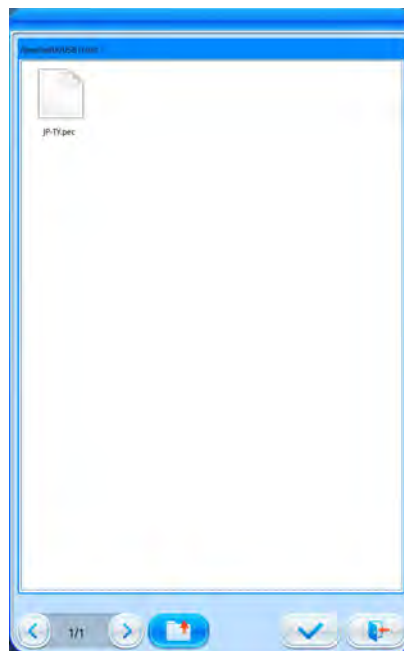

7. when system hint successful update, the update is completed.

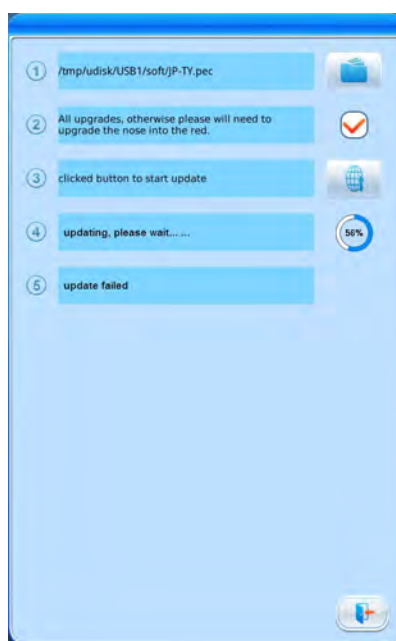



Appendix 1 Parameter List

No.	Name of Parameter	Default Value	Range of Value	Remarks
Common Parameters				
A01	Direction	P	⌈ ⌋ ⌌ ⌍ ⌎ ⌏ ⌐ ⌑ ⌒ ⌓ ⌔ ⌕ ⌖ ⌗ ⌘ ⌙ ⌚ ⌛ ⌜ ⌝ ⌞ ⌟ ⌠ ⌡ ⌢ ⌣ ⌤ ⌥ ⌦ ⌧ ⌨ 〈 〉 ⌫ ⌬ ⌭ ⌮ ⌯ ⌰ ⌱ ⌲ ⌳ ⌴ ⌵ ⌶ ⌷ ⌸ ⌹ ⌺ ⌻ ⌼ ⌽ ⌾ ⌿ Ⓚ Ⓛ Ⓜ Ⓝ Ⓞ Ⓟ Ⓠ Ⓡ Ⓢ Ⓣ Ⓤ Ⓥ Ⓦ Ⓧ Ⓨ Ⓩ ⓐ ⓑ ⓓ ⓔ ⓖ ⓗ ⓘ ⓙ ⓚ ⓛ ⓜ ⓝ ⓞ ⓟ ⓠ ⓡ ⓢ ⓣ ⓤ ⓥ ⓦ ⓧ ⓨ ⓩ ⓪ ⓫ ⓬ ⓭ ⓮ ⓯ ⓰ ⓱ ⓲ ⓳ ⓴ ⓵ ⓶ ⓷ ⓸ ⓹ ⓺ ⓻ ⓼ ⓽ ⓾ ⓿	
A02	Rotate	0	0~89	Rotating angle of the design
A03	X&Y Scales	100/100	50%~200%	Scale ratio of design in X /Y direction
A04	Prior Mode	Rotate	Rotate, Scale	
A05	Rep. Mode	Normal	Normal Part	Not used
A06	Rep. Prior	X Prior	X prior, Y prior	
A07	X&Y Repts	1/1	1~99	
A08	X&Y Interval	0.0/0.0	-999.9~+999.9	
Embroidery Assistant Parameters				
B01	Auto Origin	Yes	No, Yes	
B02	To Do Cyclic Emb.	No	No, Yes	Whether to automatically repeat embroidering the design. It often accompanies repetition or the special design.
B13	Start for Same Colors	Yes	No, Yes	Whether to start in color-changing way when the later needle position is same to the former one
D15	Slow STI. After Patch	0	0~3000	
D16	Speed After Patch	850	80~1000	
B18	Support 3D?	Yes	No, Yes	
C77	Filter Short Stitch	Yes	No, Yes	It is fit for high-speed machine using dahao servo-motor driver. It only get effective after user confirm the embroidery again.
C78	Filtering Short Sti Len	0.5mm	0.1mm~0.6mm	The same as above
C80	Auto Jump Stitch Len	6mm	6.0mm~12.0mm	The same to above
U57	Speed of Fast Idling	10	1~10	
L02	Embroidery	No	No, Yes	



Appendix 2 Directions of U Disk Operation

No.	Name of Parameter	Default Value	Range of Value	Remarks
	completed buzzer sound			
Thread-breakage Detection Parameters				
B05	T. B. Detect	No	No, Yes	
B11	Sti. Not T.B. Detect	8 stitch	0 stitch ~15 stitch	
B06	Stop after T.B. detect	Yes	No, Yes	
B08	T.B. Back Sti.	0 stitch	0 stitch ~7 stitch	
B09	Back&Patch Count	2 stitch	1 stitch ~9 stitch	How many stitches to patch before the thread break point
B10	Motion After Patch	Speed Down	Speed No Change, Speed Down, Stop	
B14	Set All Heads Patch	No	No, Yes	If "Yes", all unclosed heads do patching when patching.
B12	T. B. Detect When Jump	No	No, Yes	
C28	T.B.Detect Debouncing Sti	1 stitch	1 stitch ~6 stitch	
C67	Upper Line Det. Sensitivity	3	1~10	
C68	Bobbin line Det.Sensitivity	5	1~10	
C69	Upper Line Det. Debouncing Sti	1 Sti	1~10 Sti.	
C70	Bobbin line Det. Debouncing Sti	5 Sti	1~10 Sti.	
C90	T.B.D Device Type	Wheel	Spring, Wheel, Spring+Wheel	
C91	Head motor Action Angle	0	0~10	
K1	Fault det.board type	PC2220	PC2220,Other	
L01	T.B. Sound	3 time	No voice, 1~4 time	
P05	Upper Thread Hold Solenoid Type.	Self lock	Self lock, General	



No.	Name of Parameter	Default Value	Range of Value	Remarks
Frame Parameter				
B03	Over frame by Step	No	No, Yes	
C15	High Frame-Shift Speed	16	1~30	
C16	Low Frame-Shift Speed	12	1~30	
D13	Speed When Over frame	16	0,1,2,...,30	
Main Shaft Parameters				
C07	Max. Speed	1100	250, 300, 350,...,1200	
C09	Minimum Speed	400	250,300,350,...,600	
C08	Shift Stitch Length	3	1~8	
C10	Jump Stitch Speed	600	400~850	Set the rotation speed for jump stitch.
C13	Set Run Speed	80	80, 90, ..., 150	
C12	Startup Stitches	2 stitch	1 stitch~9 stitch	Set the startup stitch number before acceleration.
D02	Startup Acce.	15	1,2,3,...,30	Increase the value to bring a quicker speedup after pressing the start key.
C25	Set Break Para.	5	0~30	Range: 0~30. When the main shaft motor is an electromagnetic motor, the value is usually set at 9. When it is a servomotor, the parameter is usually set at 5-7.
C24	Main Motor Para.	4	0~30	The parameter is invalid when it's a servomotor. When it's an electromagnetic motor, increase this parameter value to avoid main shaft vibration during braking. Usually it's set as 1.
D14	Stop Ok bef. Pull Bar	Yes	No, Yes	
D10	Ratio of AC Induction	0	-15% ~ +15%	The parameter is used when the main shaft uses induction motor. If the value is incorrect, the set rotation speed will be different from the virtual



Appendix 2 Directions of U Disk Operation

No.	Name of Parameter	Default Value	Range of Value	Remarks
				speed.
C05	Value for Thick Cloth	0	0~3	
C26	Para. Of Needle Down	15	0~30	
D53	Lock Motor When Stop	Yes	No, Yes	
C14	Speed of Slow Emb	80	80,400	
MS100	Emb.Speed	Middle	Low,Middle,H	
Thread-trimming Parameters				
C01	Jump & Trim	3 Jump	No Trim, 1 Jump~7 Jump	
D04	Speed after Trim	80	60,70,80...150	The parameter sets the rotation speed for lock stitch.
C11	Slow Stitches After Trim	3 stitch	1 stitch ~7 stitch	
C21	Length of Lock Sti. (mm)	0.6	0.3~1.5	
C19	Lock Num. After Trim	2	0~3	Set the lock stitch number at pulling the bar for embroidery after setting the trimming
D06	Spin Rounds for Brake	1	1,2	2 for most machines, 1 for mini type or machines with servo control main shaft motor.
C23	Action after Trim	Y Frame-movin g	X Frame-moving, Y Frame-moving Move Needle	
C22	Frame after Trim	No	No, Yes	
D03	Set Hold Startup Para.	-4	-4~3	
D07	Trim is OK	Yes	No, Yes	
D08	Hook Angle by Motor	-100	-100~+100	Set the hook angle by motor. When user increases the value, the hook angle is moved backward.
E39	Hook Distance By Motor	150	0~255	
C17	Pause Trimming	No	No, Yes	
C18	Trim Length	3	1~8	1 is the minimum length and 8



No.	Name of Parameter	Default Value	Range of Value	Remarks
				are the maximum length.
D05	Speed When Trimming	80	80,90,100,...,250	
C20	Lock When Trim	Yes	No, Yes	
D48	Lock Sti Len bef.Trim	0.7	0.3~2	
D49	Lock Sti bef.Trim	2	0~2	
C81	Cut action start angle	8	0~20	It is fit for the machine using stepping-motor for trimming thread.
C82	Cut return angle adj	12	0~30	The same as above.
C83	Cut keeper return angle	0	0~99	The same as above.
C84	Hold voltage adj	1	1~3	The same as above.
C95	Speed At 1st Sti. Bef. Trim	400	60~600	
C96	Speed At 2st Sti. Bef. Trim	80	60~500	
C93	When the shear line surface	Open	Open, 1 times, 2times	
C94	Emb surface clip action way	Open	Open, 1 times, 2times	
E99	Patch emb surface when fully	No	No, Yes	
H05	Trimming device type	Stepping motor	Stepping motor, Solenoid	
C110	Trim Machine Type	360	180, 360	The same as above.
P06	Stepping hook speed	3	0~5	
P07	Stepping shearing stroke	115	40~180	
Sequin Parameters (Applicable for JF Sequin)				
C31	Speed for Sequin R	400	300,310, ... ,the maximum speed	
C32	Speed for Sequin L	400	300,310, ... , the maximum speed	
D25	Sequin R Adj. Angle	0	-15~15	



Appendix 2 Directions of U Disk Operation

No.	Name of Parameter	Default Value	Range of Value	Remarks
D26	Sequin L Adj. Angle	0	-15~15	
C33	Auto Start for Sequin	No	No, Yes	
D27	Time of Sequin Action	3	0~15	Range: 0-15. For the machine using valve to move the presser, this parameter is generally set at 2~3. For the machine using stepping motor to move the presser, this value is set at 4~5.
C34	Sequin Up after T.B.	No	No, Yes	It is used to control the position of the sequin device after thread-breakage
C56	Sequin Ind. Up Down	No	No, Yes	
B17	Up Valve When Jump & No cut	Yes	No, Yes	
D61	Motor Number of L Sequin		No,1~4	
D54	Motor Number of R Sequin		No,1~4	
D84	L Knife Start Angle Adj	1	0~31	
D83	R Knife Start Angle Adj	1	0~31	
D99	R.Knife Start Angle Adj.	2	0~10	
JF40	Sequin R 2MM Dir/Ang	Double-ways /18	One-way 5.4 ~ 62.2 angle; Double-ways 5.4~62.2 angle	
D55	Sequin R 3MM Dir/Ang	Double-ways /11.7	One-way 5.4 ~ 62.2 angle; Double-ways 5.4~62.2angle	
D56	Sequin R 4MM Dir/Ang	Double-ways /11.7	One-way 5.4 ~ 62.2 angle; Double-ways 5.4~62.2 angle	
D57	Sequin R 5MM Dir/Ang	Double-ways /18	One-way 5.4 ~ 62.2 angle; Double-ways 5.4~62.2 angle	
D58	Sequin R 6.75MM Dir/Ang	Double-ways /21.6	One-way 5.4 ~ 62.2 angle; Double-ways	



No.	Name of Parameter	Default Value	Range of Value	Remarks
			5.4~62.2 angle	
D59	Sequin R 9MM Dir/Ang	Double-ways /36	One-way 5.4 ~ 62.2 angle; Double-ways 5.4~62.2 angle	
C57	A Size&Color of R Sequin	4mm yellow	3/4/5/6.75/9mm Light gray/gold/red /green/blue/purple/yell ow/cyanogen	
C58	B Size&Color of R Sequin	4mm blue	3/4/5/6.75/9mm Light gray/gold/red /green/blue/purple/yell ow/cyanogen	
C59	C Size&Color of R Sequin	5mm cyanogen	3/4/5/6.75/9mm Light gray/gold/red /green/blue/purple/yell ow/cyanogen	
C60	D Size&Color of R Sequin	6.75mm gold	3/4/5/6.75/9mm Light gray/gold/red /green/blue/purple/yell ow/cyanogen	
D67	Sequin Gap Num of R Sequin	No	No, 1,2	
C66	Valve Time of Right Sequin	0	0~5	
JF41	Sequin L 2MM Dir/Ang	Double-ways /18	One-way 5.4 ~ 62.2 angle; Double-ways 5.4~62.2 angle	
D62	Sequin L 3MM Dir/Ang	Double-ways /11.7	One-way 5.4 ~ 62.2 angle; Double-ways 5.4~62.2 angle	
D63	Sequin L 4MM Dir/Ang		One-way 5.4 ~ 62.2 angle; Double-ways 5.4~62.2 angle	
D64	Sequin L 5MM Dir/Ang		One-way 5.4 ~ 62.2 angle; Double-ways 5.4~62.2 angle	
D65	Sequin L 6.75MM Dir/Ang		One-way 5.4 ~ 62.2 angle; Double-ways 5.4~62.2 angle	
D66	Sequin L 9MM Dir/Ang		One-way 5.4 ~ 62.2 angle; Double-ways 5.4~62.2 angle	



Appendix 2 Directions of U Disk Operation

No.	Name of Parameter	Default Value	Range of Value	Remarks
C61	A Size&Color of L Sequin	3mm yellow	3/4/5/6.75/9mm Light gray/gold/red /green/blue/purple/yell ow/cyanogen	
C62	B Size&Color of L Sequin	4mm blue	3/4/5/6.75/9mm Light gray/gold/red /green/blue/purple/yell ow/cyanogen	
C63	C Size&Color of L Sequin	5mm purple	3/4/5/6.75/9mm Light gray/gold/red /green/blue/purple/yell ow/cyanogen	
C64	D Size&Color of L Sequin	6.75mm gold	3/4/5/6.75/9mm Light gray/gold/red /green/blue/purple/yell ow/cyanogen	
D67	Sequin Gap Num of L Sequin	No	No, 1,2	
C66	Valve Time of Left Sequin	0	0~5	
JF01	Right Cutting Range	15	0~31	
JF02	Left Cutting Range	15	0~31	
JF03	Right Sequine Select	All	All, Direct AB, Side CD	
JF04	Left Sequine Select	All	All, Direct AB, Side CD	
JF05	Start Angle of Right Cutter	15	0~31	
JF06	Start Angle of Left Cutter	15	0~31	
JF07	Insert Empty Neddle Before Sequin	No	Yes, No	
JF08	Sequin Device Life Mode	Independen	Independen, Concentrate	
SH01	Single needle head work group	4	0~30	
SH02	Single needle head	Needle 5	No, 1~15	



No.	Name of Parameter	Default Value	Range of Value	Remarks
	work needle pos			
SH03	Single needle head working mode	Sequin + Glass Beads	Sequin + Glass Beads, Pure Sequin, Pure Glass Beads	
SH04	Sequin retract motor start angle adjustment	10	0~200	
SH05	Single needle head sequin working mode	Big piece	general, Big piece	
SH06	Single needle sequin head working mode	R Sequin	R Sequin, L Sequin, R Sequin + L Sequin	
Taping Parameter				
D86	A-Zig Emb.Right On/Off	Yes	Yes(First Stitch), No	
D87	A-Zig Emb.Left On/Off	Yes	Yes(Last Stitch), No	
D88	A-Zig Emb. On/Off Time	2		
C35	A-Zig Max Speed	400	300~850	
D29	A-Zig Swing Angle	0	0~125	
C38	A-Zig 5 Swing Angle	0.2	0.2~10	
D93	A-Zig T.L Adj	5	0~10	
D95	A-TAPING Emb.righe origin pos.	0	0~100	
D96	A-TAPING Emb.left origin pos.	0	0~100	
D81	A-Zig great efficiency mode	5	1~5	
ST01	Work mode	2	1~5	
ST02	Actuation time adj.	1	1~20	
ST03	Looped time	50	30~100	
ST04	Whether cut line when jump	No	Yes, No	
ST05	Threading point position	String position	Thick rope position, String position	



Appendix 2 Directions of U Disk Operation

No.	Name of Parameter	Default Value	Range of Value	Remarks
ST07	Thread Broken Test Sensitivity	1	1~10	
GlassBead Parameters				
E80	Send beads angle for motor L	30	1~100	
E81	Recv beads angle for motor L	50	1~50	
E82	Angle for L clip motor	30	1~50	
E83	Adj speed of L soeed motor	8	0~15	
E84	Adj speed of L conveyor motor	8	0~15	
E85	Adj speed of L add-power motor	8	0~15	
E86	Time para for L bead	24	1~50	
E87	Time para for L sequin	15	1~50	
E88	Count of L bead motor	None	None, Yes	
GB02	Left Bead Turntable Action Time	5	1~10	
E89	Send beads angle for motor R	61	1~100	
E90	Recv beads angle for motor R	10	1~50	
E91	Angle for R clip motor	18	1~50	
E92	Adj speed of R soeed motor	8	0~15	
E93	Adj speed of R conveyor motor	8	0~15	
E94	Adj speed of R add-power motor	8	0~15	
E95	Time para for R bead	24	1~50	
E96	Time para for R sequin	15	1~50	
E97	Count of R bead	None	None, Yes	



No.	Name of Parameter	Default Value	Range of Value	Remarks
	motor			
GB03	Right Bead Turntable Action Time	5	1~10	
E98	All head change bead cnt	0	1~2500	
H03	Angle of glass-bead arriving	0	0~359	
H04	Bead more revolutions	8	0~15	
GB04	Whether to insert bead code or not	No	No, Yes	
Taping Embroidery Parameter				
C55	M Axis Origin At T.B.	Yes	No, Yes	
C54	Cord Emb. Needle	Yes	No, Yes	
C37	M Axis Stop to Origin	Yes	No, Yes	
D28	Special Head Interval	10	10~1000	
D30	Clamp Foot Displace	0	0~90	
D40	Adj Clamp Foot Limit	170	0~250	
B16	Clamp Foot Min Height Adj	0	0~255	
D31	Rod Pos. of Zigzag	Left	Left/Right	
D29	Zigzag Swing Angle	90	0~90	
C38	Swing Value of Zigzag	0.2	0~10	
D50	Adj Z Emb Swing	0	0~5	
D42	Rotary Gap of M Axis	0	0~10	
D44	M Axis Work OFF Angle	0	0, 90	
C39	Spec. Emb. Trim Mode	No Trim	Low, Above & Low, No Trim	
C35	Speed for Sequin L	400	300~850	



Appendix 2 Directions of U Disk Operation

No.	Name of Parameter	Default Value	Range of Value	Remarks
C51	Spec Minimum Speed	250	250~400	
C52	Spec. Speed-Down Angle	30	1~180	
C53	Spec. Speed-Down Ratio	1	1~4	
D39	Z Shift Control Angle	0	0~180	
D41	Adj Zigzag Rod Angle	3	1,2,3	
C36	Ratio of Coil Emb.	1 Sti/L	1~4 Sti/L	
D47	Slow Down When Coil Emb	Yes	No, Yes	
Machine Parameters				
D01	Needles	6	1,2,...,MAXNEEDLE	Set the value according to the machine situation. E.g. the value should be 9 for 9-needle machine. If the value is different from the machine needles, the color changing will be abnormal.
D12	Color-Change Speed	12	0~30	
K2	Openloop stepper change color curve	0	0~7	
C43	IP Address			It is used for setting machine address when connected to PC. It is not different among different machines.
C45	Subnet mask			It is used for setting the subnet mask of IP address when connected to PC.
C46	Gateway			It is used for setting the gateway of machine when connected to PC.
Z02	DNS Server			
Z03	Start DHCP	No	No, Yes	
C49	X Coarse and Fine Adjustment	0	0,1	
C50	Y Coarse and Fine Adjustment	0	0,1	

Appendix 1 Parameter List



No.	Name of Parameter	Default Value	Range of Value	Remarks
C29	Needle of Boring	No	No, 1~7	
C71	Thread hold voltage adj.	1	1~10	
E1	DIP1	0	0~255	
E2	DIP2	0	0~255	
E3	DIP3	0	0~255	
E4	DIP4	0	0~255	
H06	Drive failure monitoring	Yes	No, Yes	
M100	Start needle light	No	No, Yes	
K3	Hat emb Speed limit	800	80~800	
D68	Number of heads	1	1~4	
E45	Machine head distance	162	1.0~1500.0	
C29	Carving Needle Pos.	None	None, 1~15	
C30	Boring Emb. Disp.	0	0~12	
C41	Server Port	1600	1~9999	It is used for setting sever port when it is connected to PC.
C44	Srver IP	0.0.0.0		
Y001	X/Y Limit Position	X Right Y Back	X Right Y Back, X Right Y Front, X Left Y Back, X Left Y Front,	
Y002	X/Y Limit Origion	X+Y+	X+Y+, X+Y-, X-Y+, X-Y-	
Y003	X/Y Limit Origion Detection Mode	X Double Y Double	X Double Y Double, X Double Y Single, X Single Y Double, X Single Y Single	
Z01	Turn on infrared protection	No	No, Yes	
PC2220 Set				
P01	Color motor current	2	0~3	
P02	Trim motor current	2	0~3	
P03	Hook motor current	2	0~3	
P04	Head motor current	2	0~3	



Appendix 2 Directions of U Disk Operation

No	Operations	Methods or Standards	Remarks
1	USB I/O	Same as floppy disk	
2	Operation priority between USB disk and floppy disk	USB Disk	
3	Format supported by USB disk	FAT16 and FAT32	
4	Support long file name	Support, but not displayed	
5	File name format	DOS 8.3 mode (8 digit prefix is viewable,suffix is 3 digits)	For instance: “清明上河图.DST” will be displayed as “清明上~1.DST”
6	Support file name in Chinese	Support	
7	Sub-directory operation	Support	
8	Sub-directory limitation	No. It could be countless in theory	
9	File number in one sub-directory	400	
10	Reading & writing error/ change USB	Back to disk management or design management interface, insert the disk again.	
11	Multi-logical disks in one USB	Support	
12	Formatting USB	Support	
13	Installation of the letter base	Not Support	
14	Software update	Support	
15	Special character in file name	Support, except “\$”.	





Appendix 3 Automatic Position Limitation Function Instructions for Apparel Embroidery



A、Working Principle

The automatic position limitation function of single-head embroidery machine controller is to determine the embroidery range of the frame by setting the distance from the center of the frame to the origin (that is X-/Y position limitation optical coupler) and the actual frame size (unit: mm). If embroidery is to be done beyond such range, the controller will activate automatic protection to prevent damage to the mechanical parts of the embroidery machine.

B、Setting Method

1. Press " " key to enter the frame selection and position.
2. Press  to enter frame parameter setting interface.



3. Press “Auto Frame Origin”  and then press “”. At this moment, the frame will automatically find the origin and confirm it.



Question

Seek Frame Origin, be careful, frame moving, and judge the cap frame, remove it if necessary!

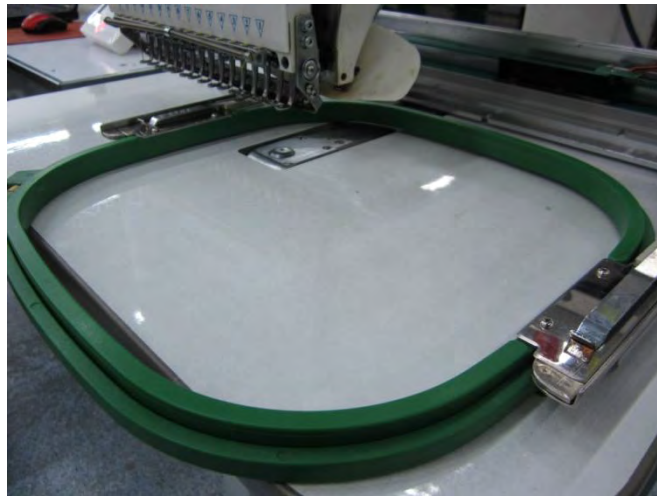

4. Clear the XY Displacement



5. Manual Frame-moving



In the frame parameter setting interface, click the frame-moving key to move the frame to overlap its center with the needle hole.

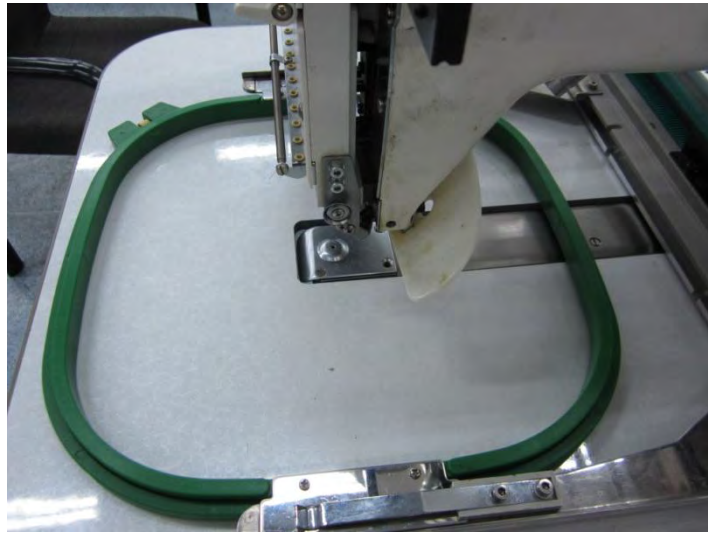

6. Set Frame Center and Size

In the frame parameter setting interface, check the coordinates of XY, which is the position of frame center.



Press "" key, where user can input the coordinates of XY in the frame parameter setting interface.



There are four parameters: "X direction center" means the distance at X direction between the frame center and X- direction position limitation optical coupler; "Y direction center" means the distance at Y direction between the frame center and Y+ direction position limitation optical coupler. "X direction frame size" means the embroidery range of the frame at X direction; "Y direction frame size" means the embroidery range of the frame at Y direction.

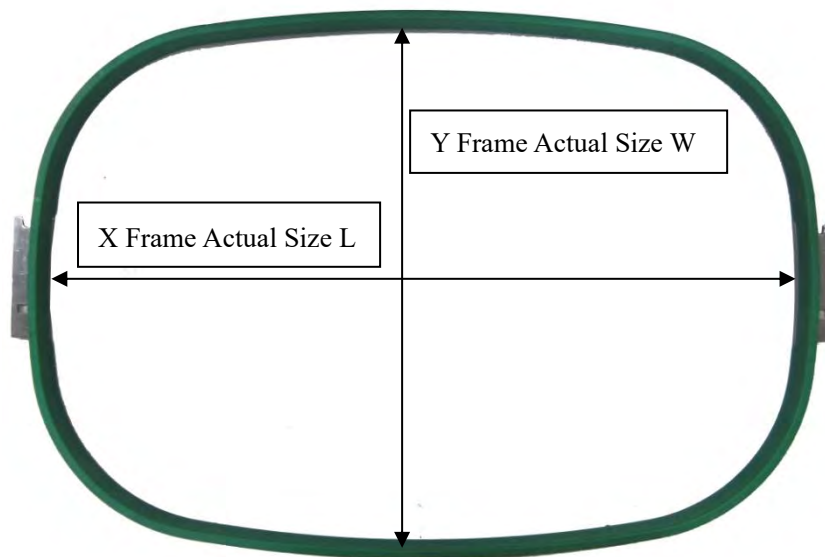

"X direction frame size" and "Y direction frame size" should be set according to the actual size of different frames. Note: this parameter need be set according to the actual embroidery range of the frame, for the apparel frame is usually not square.

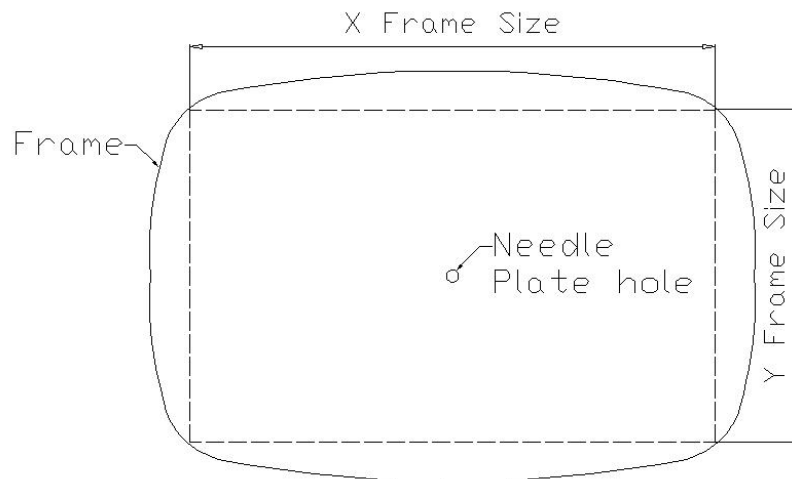

C、Cancel Position Limitation

Set "Frame Selection" as "No Frame", the position limitation function will be canceled and the software protection for the frame of flat embroidery will also become invalid.





D、Common Frame Size (Unit: mm)

Frame 1:

Size: 550×375

Embroidery Range: 430×260

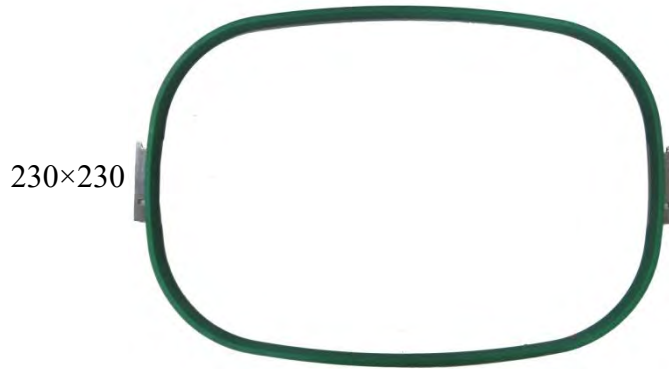

Frame 2:

Size: 290×290

Embroidery Range:



Frame 3:

Size: 200

Embroidery Range: 150



Frame 4:

Size: 150

Embroidery Range:



Frame 5:

Size: 120

Embroidery Range: 90



Frame 6:

Size: 90

Embroidery Range:



Appendix 4 A15Pro-FW Controller Operation Quick Guide



Part I. Embroidery

Pattern Management "  ": memory pattern preview, letter pattern operation, delete pattern, pattern input/output, pattern function setting, etc.

A. Input Pattern

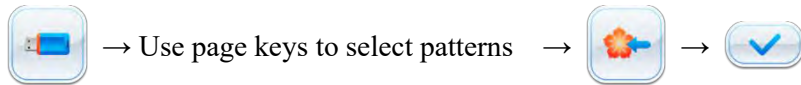

Common Parameter Setting  : direction, angle, X/Y scaling, priority setting, etc.

C. Modify Embroidery Parameters: A01-A08: click to set.

Main Interface "  ": thread trimming, main shaft jog, frame setting, color-changing and start mode setting, manual frame-moving, speed adjustment, empty feed, etc.

E. Frame Selection and Position



F. Embroidery Confirmation

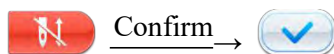

G. Start Embroidery



H. Release Embroidery Confirmation



If user, after releasing embroidery confirmation, wants to embroider the pattern again, user need operate from step B "Select Pattern for Embroidery" again.

Part II. Manual Operation

A. Manual Trimming



B. Manual Color-changing



C. Main Shaft Jog



D. Manual Frame-moving

Direction Keys: , , , ; Speed Shift Key: , 

E. Empty Feed

1. Empty Feed and Return at Low Speed



2. Empty Feed and Advance at low Speed



3. Locate the Last Color-changing Code



5. Empty Feed and Return at High Speed



7. Return to Embroidery Start Point



4. Locate the Next Color-changing Code



6. Empty Feed and Advance at High Speed



8. Return to Embroidery Stop Point

